

PDR 200, PDR 300, & PDR 400  
**Installation Manual**

071-8005-00  
MARCH 23, 2000

**PROFILE FAMILY**  
VIDEO FILE SERVERS

## Copyright

Copyright © 2000 Grass Valley Group Inc. All rights reserved. Printed in the United States of America.

This document may not be copied in whole or in part, or otherwise reproduced except as specifically permitted under U.S. copyright law, without the prior written consent of Grass Valley Group Inc., P.O. Box 59900, Nevada City, California 95959-7900

## Trademarks

Grass Valley, GRASS VALLEY GROUP, Profile and Profile XP are either registered trademarks or trademarks of Grass Valley Group in the United States and/or other countries. Other trademarks used in this document are either registered trademarks or trademarks of the manufacturers or vendors of the associated products. Grass Valley Group products are covered by U.S. and foreign patents, issued and pending. Additional information regarding

Grass Valley Group's trademarks and other proprietary rights may be found at [www.grassvalleygroup.com](http://www.grassvalleygroup.com).

## Disclaimer

Product options and specifications subject to change without notice. The information in this manual is furnished for informational use only, is subject to change without notice, and should not be construed as a commitment by Grass Valley Group. Grass Valley Group assumes no responsibility or liability for any errors or inaccuracies that may appear in this publication.

## U.S. Government Restricted Rights Legend

Use, duplication, or disclosure by the United States Government is subject to restrictions as set forth in subparagraph (c)(1)(ii) of the Rights in Technical Data and Computer Software clause at DFARS 252.277-7013 or in subparagraph c(1) and (2) of the Commercial Computer Software Restricted Rights clause at FAR 52.227-19, as applicable. Manufacturer is Grass Valley Group Inc., P.O. Box 59900, Nevada City, California 95959-7900 U.S.A.

## Revision Status

REV DATE	DESCRIPTION
April, 1997	Initial release of Installation Manual 070-9676-00
May, 1997	Procedure change, roll Part Number to 070-9676-01
September, 1997	Add Analog Composite I/O and Monitor Boards, remove Fibre Channel user information, roll P/N to 070-9676-02
January, 1998	Change slot positions for systems above S/N B030000, roll P/N to 070-9676-03
June, 1998	Added PDR300 with MPEG, PDR200 slot positions change for systems above S/N B040000, roll P/N to 070-9676-04.
October, 1998	Added support for PDR200 Option DV and PDR304. Roll P/N to 070-9676-05.
November, 1998	Modified sections to support changes to the CPU board for PDR200 systems above S/N B050000 and PDR300 systems above S/N B020000. Roll P/N to 070-9676-06.
December, 1998	Modified sections to support 18GByte drives, for PDR200 systems above S/N B060000 and PDR300 systems above S/N B030000. Roll P/N to 070-9676-07.
April, 1999	Modified manual title and added support for the PDR400 with DVCPRO. Roll P/N to 070-9676-08
October, 1999	Added six-channel DVCPRO support. Roll P/N to 070-9676-09.
March 23, 2000	Added DVCPRO 50 support. New P/N to 071-8005-00.

---

# Grass Valley Group Product Support

You can get technical assistance, check on the status of problems, or report new problems by contacting our Product Support Group.

## United States and Canada

Monday–Friday 5:30AM–5:00PM Pacific Time  
(800) 547-8949

## Europe

Monday–Friday 9:00AM–5:30PM

France	01 69 86 83 47	United Kingdom	01628 405830
Germany	0221 9477 446	Other	+44 1628 405840
Italy	02 25086606		

## Asia and South America

Australia	02-9888 0100	Japan	81-3-3448-3111
- from overseas	61-2-9888 0100	Korea	82-2-528-5299
Beijing	86-10-62351230	Mexico	52-5-666-6333
	ext. 711	Singapore	65-356-3900
Brazil	55-11-3741-8422	Taiwan	886-2-27571571
Hong Kong	852-25856655		

## World Wide

**24-hour Emergency Hotline (530) 478-4148** (Contract and warranty customers)

<b>World Wide Web</b>	<a href="http://www.grassvalleygroup.com/support/">http://www.grassvalleygroup.com/support/</a>
<b>FTP Site</b>	<a href="ftp.grassvalleygroup.com">ftp.grassvalleygroup.com</a>
<b>Users Group</b>	<a href="mailto:profile-users@grassvalleygroup.com">profile-users@grassvalleygroup.com</a>



---

# Contents

	Grass Valley Group Product Support .....	iii
<b>Chapter 1</b>	<b>Introduction</b>	
	Scope .....	1-1
	Related Documentation .....	1-2
	Organization of the Manual .....	1-2
	Product Description .....	1-3
	Product Features .....	1-4
	Front Panel Controls and Indicators .....	1-5
	Accessories .....	1-6
	Standard Accessories .....	1-6
	Optional Accessories .....	1-7
	Configurations .....	1-8
	Configuration Labels .....	1-14
	Maximum Video Data Rates .....	1-15
	Storage Capacity Estimates .....	1-16
	DVCPRO System Timing Considerations .....	1-17
<b>Chapter 2</b>	<b>Mechanical Installation</b>	
	Rack Mounting .....	2-1
	Mounting the Slide Tracks in the Rack .....	2-2
	Mounting the Profile Video File Server .....	2-5
	Making Rack Slide Adjustments .....	2-6
	Mounting Panels and Audio Chassis .....	2-6
	Making Rear Panel Connections .....	2-7
	Connecting the Mouse and Keyboard .....	2-8
	Connecting the Monitor .....	2-8
	Connecting the Reference Genlock .....	2-9
	Connecting Video .....	2-10
	Connecting Serial Digital Video .....	2-10
	Connecting Analog Composite Video I/O .....	2-11
	Connecting Analog Composite Monitor .....	2-12
	Connecting Analog Composite Video Out .....	2-13
	Connecting Component Analog Video .....	2-14
	Connecting Audio .....	2-15
	Connecting 16 Channels AES/EBU Digital Audio (XLR216 or BNC216) .....	2-16
	Connecting 32 Channels AES/EBU Digital Audio (XLR216 or BNC216) .....	2-18
	Connecting 8 Analog and 8 Digital Channels (PAC208) .....	2-20
	Connecting 16 Analog/Digital Channels (PAC216) .....	2-22
	Connecting 32 Analog/Digital Channels (PAC216) .....	2-24
	Connecting SCSI Devices .....	2-26
	Connecting RS-422 Devices .....	2-32
	Connecting Network Devices .....	2-33
	Connecting Fibre Channel .....	2-33
	Connecting to Ethernet .....	2-33
	Making Power Connections .....	2-34
	Power Source .....	2-34
	Source Power Frequency and Voltage Ranges .....	2-34



<b>Chapter 3</b>	<b>Starting Your Profile System</b>	
	Power On/Off .....	3-1
	Logging On .....	3-1
	Automatic Logon .....	3-1
	Logon as Administrator .....	3-2
	Logon as Profile .....	3-2
	Turning Power On .....	3-2
	Turning Power Off .....	3-4
	System Set-up .....	3-5
	Configuring Your Profile System .....	3-6
	Updating an Emergency Repair Disk .....	3-6
	Installation Verification .....	3-7
	Initial Power On Checks .....	3-7
	System Board Diagnostics .....	3-9
<b>Chapter 4</b>	<b>Networking Your Profile System</b>	
	Network Configurations .....	4-1
	Network Models .....	4-1
	Networking Several Profile Systems .....	4-2
	Cascading Several Hubs .....	4-2
	Point to Point Network Connection .....	4-3
	Connecting Ethernet .....	4-4
	Ethernet Interface Configuration .....	4-4
	Configuring Ethernet for TCP/IP .....	4-5
	Testing Your Ethernet Connection .....	4-5
	Connecting Fibre Channel .....	4-6
<b>Appendix A</b>	<b>Specifications</b>	
	General Information .....	A-1
	Test Equipment .....	A-1
	Electrical Specifications .....	A-2
	Environmental Criteria .....	A-10
	Mechanical Specifications .....	A-11
	PAC 208/216 Power Requirements .....	A-11
<b>Appendix B</b>	<b>Connector Pin-outs</b>	
	S-VGA Connector .....	B-1
	Ethernet Connector .....	B-2
	Parallel Port Connector .....	B-3
	RS-232 Connectors .....	B-4
	SCSI Connector .....	B-5
	Fibre Channel Connector .....	B-7
	Fibre Channel Cable Specifications .....	B-7
	Reference Genlock D-Connector .....	B-8
	Audio Signal Processing Board Connector .....	B-9

## Figures

1-1	The Profile Video File Server .....	1-1
1-2	Profile Video File Server Front Panel .....	1-5
1-3	Configuration Labels Locations .....	1-14
2-1	Rack Slide Set for Right Side of Profile Chassis and Rack .....	2-2
2-2	Spacing Specification for Mounting Holes in a Rack .....	2-3
2-3	Front Rail Mounting Detail .....	2-4
2-4	Rear Rail Mounting Detail .....	2-4
2-5	Rack Slide Stop Latch .....	2-5
2-6	BNC Connection With EMI Gasket .....	2-7
2-7	Mouse, Keyboard, and S-VGA Monitor Connections .....	2-8
2-8	Reference Genlock Cable Connections .....	2-9
2-9	Breakout Cable .....	2-9
2-10	Serial Digital I/O Cable Connections .....	2-10
2-11	Analog Composite I/O Cable Connections .....	2-11
2-12	Analog Composite Monitor Cable Connections .....	2-12
2-13	Analog Composite Out Cable Connections .....	2-13
2-14	Analog Component Video In Cable Connections .....	2-14
2-15	ASPB Connections for 16 Channels of AES/EBU Digital Audio .....	2-17
2-16	ASPB Connections for 32 Channels of AES/EBU Digital Audio .....	2-19
2-17	ASPB Connections for 8 Analog and 8 Digital Audio Channels .....	2-21
2-18	ASPB Connections for 16 Analog and 16 Digital Audio Channels .....	2-23
2-19	ASPB Connections for 32 Analog and 32 Digital Audio Channels .....	2-25
2-20	SCSI Cable Connections .....	2-26
2-21	Example 1: Connecting a PDX218 Disk Expansion Chassis .....	2-27
2-22	Example 2: Connecting two PDX218 Disk Expansion Chassis .....	2-28
2-23	Example 3: Profile Video File Server to PLS 200 Connections .....	2-29
2-24	Example 4: Profile Video File Server to PDX 218 and PLS 200 Connections .....	2-30
2-25	Example 5: Profile Video File Server to Multiple RAIDs and PLS 200 Connections .....	2-31
2-26	Profile Video File Server and RS-422 Connector Panel Cable Connection .....	2-32
2-27	Power Cord Connector .....	2-35
3-1	Rear Panel Main Power Switch .....	3-3
3-2	Front Panel Power Switch .....	3-3
3-3	Profile VdrPanel .....	3-5
4-1	Basic Hub Connections .....	4-2
4-2	Cascading Several Hubs .....	4-3
4-3	Point-to-Point Network Connection .....	4-3
4-4	System Ethernet Connector .....	4-4
4-5	Example of Profile System and Fibre Channel Connections .....	4-6
4-6	Fibre Channel Board and Hub Connection .....	4-7
B-1	S-VGA Monitor Connector .....	B-1
B-2	Ethernet RJ-45 Connector .....	B-2
B-3	Parallel Port Connector .....	B-3
B-4	RS-232 Connector Pin-outs .....	B-4
B-5	68 Pin SCSI Connector .....	B-5
B-6	Fibre Channel Connector .....	B-7
B-7	Reference Genlock 25-pin Connector .....	B-8
B-8	ASPB Connector .....	B-9



## Tables

1-1	Profile Video File Server Model Descriptions .....	1-8
1-2	PDR202 and PDR204 Factory Standard Configurations with Installable Options .....	1-9
1-3	PDR304 and PDR308 Factory Standard Configurations with Installable Options .....	1-10
1-4	PDR312 and PDR316 Factory Standard Configurations with Installable Options .....	1-11
1-5	PDR324 Factory Standard Configurations with Installable Options .....	1-12
1-6	PDR404 Factory Standard Configurations with Installable Options .....	1-13
1-7	Maximum Video Data Rates Per Channel With Non-RAID Storage .....	1-15
1-8	Maximum Video Data Rates Per Channel With PRS255 RAID Storage Chassis .....	1-15
1-9	Maximum Video Data Rates Per Channel With PRS255M RAID Storage Chassis .....	1-15
1-10	Profile Video File Server Storage Capacity Estimates .....	1-16
2-1	Audio Interface Chassis Summary .....	2-15
2-2	RS-422 Interface Board Connector .....	2-32
2-3	Power Cords for the Profile Video File Server and PAC 208 .....	2-35
3-1	Rear Panel Board Indicators .....	3-8
A-1	Serial Digital Video Input/Output .....	A-2
A-2	Analog Composite Video Output .....	A-3
A-3	Analog Composite Video I/O .....	A-4
A-4	Component Analog Video Input .....	A-5
A-5	Component Analog Video Performance .....	A-5
A-6	Format Voltage Level Definitions for CAVmtrxN Colorbar Matrix Test Clip .....	A-6
A-7	Format Voltage Level Definitions for CAVmtrxP Colorbar Matrix Test Clip .....	A-7
A-8	Program Input Genlock .....	A-8
A-9	Reference Genlock .....	A-8
A-10	Time Code .....	A-8
A-11	Analog Audio .....	A-9
A-12	Digital Audio .....	A-9
A-13	Profile Video File Server Power Source .....	A-9
A-14	Profile Video File Server Power Supply Specifications (from Manufacturer) .....	A-10
A-15	Environmental Criteria .....	A-10
A-16	Profile Video File Server Mechanical Specifications .....	A-11
A-17	PAC208/216 Power Requirements .....	A-11



# Safety Summaries

---

## General Safety Summary

Review the following safety precautions to avoid injury and prevent damage to this product or any products connected to it.

*Only qualified personnel should perform service procedures.*

While using this product, you may need to access other parts of the system. Read the *General Safety summary* in other system manuals for warnings and cautions related to operating the system.

### Injury Precautions

- |  |  |
|--|--|
| <b>Use Proper Power Cord</b>                     | To avoid fire hazard, use only the power cord specified for this product.  |
| <b>Ground the Product</b>                        | This product is grounded through the grounding conductor of the power cord. To avoid electric shock, the grounding conductor must be connected to earth ground. Before making connections to the input or output terminals of the product, ensure that the product is properly grounded. |
| <b>Do Not Operate Without Covers</b>             | To avoid electric shock or fire hazard, do not operate this product with covers or panels removed.   |
| <b>Do Not operate in Wet/Damp Conditions</b>     | To avoid electric shock, do not operate this product in wet or damp conditions.  |
| <b>Do Not Operate in an Explosive Atmosphere</b> | To avoid injury or fire hazard, do not operate this product in an explosive atmosphere.  |
| <b>Avoid Exposed Circuitry</b>                   | To avoid injury, remove jewelry such as rings, watches, and other metallic objects. Do not touch exposed connections and components when power is present.   |

### Product Damage Precautions

- |   |   |
|---|---|
| <b>Use Proper Power Source</b>                | Do not operate this product from a power source that applies more than the voltage specified.     |
| <b>Provide Proper Ventilation</b>             | To prevent product overheating, provide proper ventilation.                                       |
| <b>Do Not Operate With Suspected Failures</b> | If you suspect there is damage to this product, have it inspected by qualified service personnel. |



## Safety Terms and Symbols

### Terms in This Manual

These terms may appear in this manual:



**WARNING:** Warning statements identify conditions or practices that can result in personal injury or loss of life.



**CAUTION:** Caution statements identify conditions or practices that can result in damage to the equipment or other property.

### Terms on the Product

These terms may appear on the product:

DANGER indicates a personal injury hazard immediately accessible as one reads the marking.

WARNING indicates a personal injury hazard not immediately accessible as you read the marking.

CAUTION indicates a hazard to property including the product.

### Symbols on the Product

The following symbols may appear on the product:



DANGER high voltage



Protective ground (earth) terminal



ATTENTION – refer to manual

## Service Safety Summary

### Do Not Service Alone

Do not perform internal service or adjustment of this product unless another person capable of rendering first aid and resuscitation is present.

### Disconnect Power

To avoid electric shock, disconnect the main power by means of the power cord or, if provided, the power switch.

### Use Care When Servicing With Power On

Dangerous voltages or currents may exist in this product. Disconnect power and remove battery (if applicable) before removing protective panels, soldering, or replacing components.

To avoid electric shock, do not touch exposed connections

## Certifications and Compliances

### **Canadian Certified Power Cords**

Canadian approval includes the products and power cords appropriate for use in the North America power network. All other power cords supplied are approved for the country of use.

### **FCC Emission Control**

This equipment has been tested and found to comply with the limits for a Class A digital device, pursuant to Part 15 of the FCC Rules. These limits are designed to provide reasonable protection against harmful interference when the equipment is operated in a commercial environment. This equipment generates, uses, and can radiate radio frequency energy and, if not installed and used in accordance with the instruction manual, may cause harmful interference to radio communications. Operation of this equipment in a residential area is likely to cause harmful interference in which case the user will be required to correct the interference at his own expense. Changes or modifications not expressly approved by Grass Valley Group can affect emission compliance and could void the user's authority to operate this equipment.

### **Canadian EMC Notice of Compliance**

This digital apparatus does not exceed the Class A limits for radio noise emissions from digital apparatus set out in the Radio Interference Regulations of the Canadian Department of Communications.

Le présent appareil numérique n'émet pas de bruits radioélectriques dépassant les limites applicables aux appareils numériques de la classe A prescrites dans le Règlement sur le brouillage radioélectrique édicté par le ministère des Communications du Canada.

### **Canadian Certified AC Adapter**

Canadian approval includes the AC adapters appropriate for use in the North America power network. All other AC adapters supplied are approved for the country of use.

### **EN55022 Class A Warning**

For products that comply with Class A. In a domestic environment this product may cause radio interference in which case the user may be required to take adequate measures.

## Laser Compliance

### **Laser Safety Requirements**

The device used in this product is a Class 1 certified laser product. Operating this product outside specifications or altering its original design may result in hazardous radiation exposure, and may be considered an act of modifying or new manufacturing of a laser product under U.S. regulations contained in 21CFR Chapter 1, subchapter J or CENELEC regulations in HD 482 S1. People performing such an act are required by law to recertify and reidentify this product in accordance with provisions of 21CFR subchapter J for distribution within the U.S.A., and in accordance with CENELEC HD 482 S1 for distribution within countries using the IEC 825 standard.



**Laser Safety**

Laser safety in the United States is regulated by the Center for Devices and Radiological Health (CDRH). The laser safety regulations are published in the “Laser Product Performance Standard,” Code of Federal Regulation (CFR), Title 21, Subchapter J.

The International Electrotechnical Commission (IEC) Standard 825, “Radiation of Laser Products, Equipment Classification, Requirements and User’s Guide,” governs laser products outside the United States. Europe and member nations of the European Free Trade Association fall under the jurisdiction of the Comité Européen de Normalization Electrotechnique (CENELEC).

For the CDRH: The radiant power is detected through a 7 mm aperture at a distance of 200 mm from the source focused through a lens with a focal length of 100 mm.

For IEC compliance: The radiant power is detected through a 7 mm aperture at a distance of 100 mm from the source focused through a lens with a focal length of 100 mm.

**FCC Emission Limits**

This device complies with Part 15 of the FCC Rules. Operation is subject to the following two conditions: (1) This device may not cause harmful interference, and (2) this device must accept any interference received, including interference that may cause undesirable operation. This device has been tested and found to comply with FCC Part 15 Class B limits for a digital device when tested with a representative laser-based fiber optical system that complies with ANSI X3T11 Fiber Channel Standard.

**Certification**

Category	Standard
Safety	<p><i>Designed/tested for compliance with:</i></p> <p><b>UL1950</b> - Safety of Information Technology Equipment, including Electrical Business Equipment (Third Edition, 1995)</p> <p><b>IEC 950</b> - Safety of Information Technology Equipment, including Electrical Business Equipment (Second edition, 1991)</p> <p><b>CAN/CSA C22.2, No. 950-95</b> - Safety of Information Technology Equipment, including Electrical Business Equipment</p> <p><b>EN60950</b> - Safety of Information Technology Equipment, including Electrical Business Equipment</p>

---

# Introduction

## Scope

This is the Installation manual for the Grass Valley Group Profile Family of Video File Servers. The Profile family of products includes the PDR200 JPEG Video File Server, the PDR300 MPEG Video File Server, and the PDR400 DVCPRO Video File Server. This Installation manual provides an overview of the Profile Video File Server (shown in Figure 1-1) and descriptions of the tasks listed below:

- Installing the video file server into an equipment rack.
- Connecting Video and Audio I/O.
- Connecting SCSI devices.
- Connecting Fibre Channel and Ethernet.
- Configuring Ethernet IP Address.
- Power On/Off procedures.

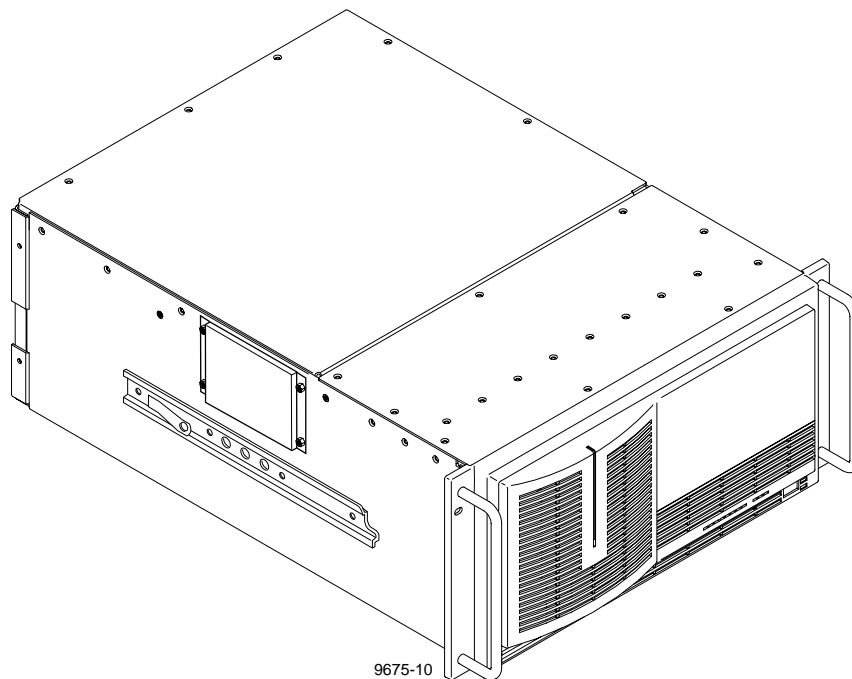

**Figure 1-1. The Profile Video File Server**



## Related Documentation

Profile Family User Manual

PDR 200 Service Manual

Profile System Software Release Notes

PDX218 Disk Expansion Chassis Instruction Manual

Windows NT Instruction Manual

## Organization of the Manual

The Installation manual is divided into the chapters identified and described below.

**Chapter 1 - Introduction:** This chapter describes the contents of the manual and provides a brief overview of the Profile Video File Server. It includes configuration and board location information.

**Chapter 2 - Mechanical Installation:** This chapter describes the physical installation of the system up to initial power-on.

**Chapter 3 - Starting Your Profile System:** This chapter consists of procedures to turn system power On and Off, to set up the system, and to verify correct installation of the Profile Video File Server.

**Chapter 4 - Networking Your Profile System:** This chapter describes the Ethernet and Fibre Channel networking used in the Profile Video File Server, including connections.

**Appendix A - Specifications:** This appendix consists of physical and electrical specifications and environmental criteria.

**Appendix B - Connector Pin-outs:** This appendix identifies certain connectors and the signals present and the pins of those connectors.

## Product Description

The Profile Video File Server is a disk-based video file server with enhanced record and playback quality, and rapid storage/retrieval capabilities. In addition to the advantage of not having to load tape as with VTRs, the Profile Video File Server occupies less rack space and is fully computer controlled.

The PDR200 provides up to four Motion-JPEG encoders/decoders (CODECs) in a flexible system which starts with four base configurations: two are for 2-channel Profile systems and two are for 4-channel Profile systems. These base configurations can be ordered with analog or digital inputs and outputs. Each configuration is then tailored, through factory installed options, to meet your site-specific needs. Many options may be easily added to your PDR 200 as your needs change and expand. For information on adding options, contact your Grass Valley Group representative.

A two-channel system (PDR202) is equipped with a single Master Enhanced Disk Recorder board, which provides two JPEG codecs, and two SCSI busses, SCSI A and SCSI B, although SCSI B may not be available on all models. A four-channel system (PDR204) adds a Slave Enhanced Disk Recorder, which provides two additional JPEG codecs and two more SCSI busses (SCSI C and SCSI D).

The PDR300 adds factory-installed MPEG encoders and decoders to the Profile Video File Server, while retaining all the capabilities and optional configurations of the PDR200. Two MPEG boards, one with one encoder and two decoders, the other with four decoders, provide many combinations of capabilities to meet your needs. The JPEG codecs on the Master and Slave Enhanced Disk Recorder boards remain available as resources for record/play channels or for transcoding clips between JPEG and MPEG.

The PDR400 adds factory-installed DVCPRO boards to the Profile Video File Server, while retaining the same capabilities and optional configurations of the PDR200. The DVCPRO boards includes up to six DVCPRO 25 codecs arranged in pairs. Each pair of DVCPRO 25 codecs may be used as a single DVCPRO 50 codec. Because of this paired codec architecture, some system timing restrictions apply. These restrictions are discussed in “DVCPRO System Timing Considerations” on page 1-17. The JPEG codecs on the Master and Slave Enhanced Disk Recorder boards remain available as resources for record/play channels or for transcoding clips between JPEG and DVCPRO. In some configurations, the operation of one of the JPEG codecs may be restricted as described in “Configurations” on page 1-8.

The Profile Video File Server is mounted on rack slides for installation in a standard electronic equipment rack. All connections to the Profile Video File Server are on the rear panel (see Chapter 2, “Mechanical Installation”). Also see Appendix A, “Specifications”, for physical and electrical specifications and environmental criteria.



## Product Features

Record/playback and storage/retrieval applications for the Profile Video File Server run in the Windows NT™ environment. The Windows NT operating software is loaded on the dedicated system hard disk, which is also used for application storage. Control is via an internal Pentium-based CPU board.

Other features include:

- Super-VGA monitor output
- Auto switching 10/100BASE-T Ethernet network support
- Control interfaces:
  - RS-232 (two rear panel ports)
  - RS-422 (eight ports through breakout panel)
  - Keyboard and mouse
  - Parallel port
- Front panel controls and indicators.



## Front Panel Controls and Indicators

The Profile Video File Server front panel, shown in Figure 1-2, consists of the controls and indicators keyed to Figure 1-2 and briefly described below.

- ❶ Floppy Disk Drive access for loading operating system software or specific application software. The drive accepts standard 3-1/2-inch double density (720KB) or high density (1.44MB) floppy diskettes.
- ❷ Green LED indicator lighted when both the power switch on the rear panel and the one on the front panel (see ❺ below) are On.
- ❸ Eight green LED indicators, labeled **DISK ACCESS**, show disk activity. They are mapped right to left to the physical location of each hard disk drive in the chassis and flash on when activity occurs on the associated disk. A LED should flash on for every disk installed in the unit. If a LED fails to flash on for each disk in the unit or if a LED remains lit, there may be a problem with the one of the disks. If you do not have any internal disk storage, which is an option, these LEDs remain off.
- ❹ Three red Trouble LED indicators. When lighted they provide warnings of (from the left):
  - SYS FAULT** (not used)
  - FAN FAULT** (failure of one or more fans)
  - OVER TEMP** (power supply over temperature)
- ❺ The **STANDBY/ON** switch provides system On/Off control (the same as pressing the rear panel On/Off switch). Both must be On for operation of the Profile Video File Server.

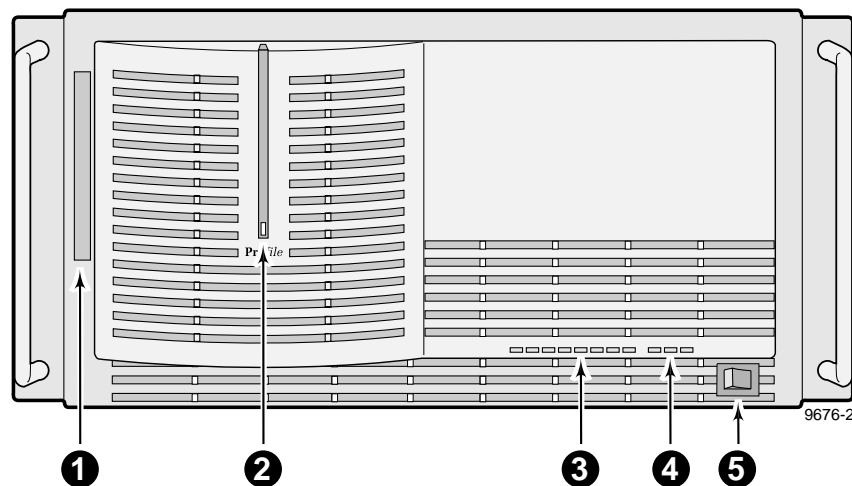

Figure 1-2. Profile Video File Server Front Panel



## Accessories

There are two types of accessories for the Profile Video File Server: Standard and Optional. Standard Accessories are those items required to install and operate the Profile Video File Server. They are shipped with your Profile system. Optional accessories expand Profile Video File Server capabilities, simplify installation, or aid in servicing. Optional accessories are available through Grass Valley Group.

### Standard Accessories

A Profile Video File Server shipment includes the following items:

- 1 Manual, Profile Family User
- 1 Manual, Installation
- Profile System Software Release Notes
- Software Package which includes the latest version of Profile System Software and an Emergency Repair diskette.
- Windows NT software package
- 1 Keyboard (Grass Valley Group part number 119-4899-XX)
- 1 Mouse (Grass Valley Group part number 119-4330-XX)
- EMI Suppression Gaskets for BNC Connectors (Grass Valley Group part number 016-1448-XX)
- Cable Assemblies, Power (161-0123-00 for US and Japan; 161-0066-09 for Europe; 161-0066-10 for the United Kingdom; or 161-0066-11 for Australia)
- 1 RS-422 Connector Panel and cable
- 1 Set of rack-mounting slides
- Ethernet cable

## **Optional Accessories**

If ordered, Grass Valley Group provides the optional accessories listed below. Contact your nearest field office or distributor for more information.

- Ethernet Hub (for Ethernet connections)
- Fibre Channel Hub (for Fibre Channel networking)
- Optical Media Interface Adapter (copper-to-fiber) for fibre channel networking.
- S-VGA Monitor
- PAC208/216 Analog/Digital Profile Audio Chassis
- XLR216 or BNC216 Digital Audio Breakout Panel
- PDX218 Disk Drive Expansion Chassis
- 1 SCSI Terminator (011-0166-00)
- Eight-connector DB25-XLR breakout cable for longitudinal time code I/O, 6 ft. (Grass Valley Group part number 174-3249-XX)
- Eight-connector breakout cable, with DB25 connector, 24 ft. (Grass Valley Group part number 174-3481-XX)
- External CD ROM drive (Grass Valley Group part number PDRFCD)
- Service Manual (070-9675-XX)



## Configurations

The Profile Video File Server is available in several factory installed configurations. Table 1-1 lists the available JPEG codecs, MPEG encoders, MPEG decoders and DVCPRO25 codecs that are available on each model.

**Table 1-1. Profile Video File Server Model Descriptions**

Model Number	Number of JPEG CODECs	Number of MPEG Encoders	Number of MPEG Decoders	Number of DVCPRO25 CODECs	Video I/O Type
PDR202A	2	0	0	0	Analog
PDR204A	4	0	0	0	Analog
PDR202D	2	0	0	0	Digital
PDR204D	4	0	0	0	Digital
PDR304A	2	0	4	0	Analog
PDR304D	2	0	4	0	Digital
PDR308A	2	0	8	0	Analog
PDR308D	2	0	8	0	Digital
PDR312A	2 <sup>a</sup>	1	2	0	Analog
PDR312D	2 <sup>a</sup>	1	2	0	Digital
PDR316A	2 <sup>a</sup>	1	6	0	Analog
PDR316D	2 <sup>a</sup>	1	6	0	Digital
PDR324A	4	2	4	0	Analog
PDR324D	4	2	4	0	Digital
PDR404A	4 <sup>b</sup>	0	0	4	Analog
PDR404D	4 <sup>b</sup>	0	0	4	Digital
PDR406A	4 <sup>b</sup>	0	0	6	Analog
PDR406D	4 <sup>b</sup>	0	0	6	Digital

<sup>a.</sup> 4 if Slave Disk Recorder is installed

<sup>b.</sup> If JPEG #2 and DVCPRO25 #4 are used, they must both be connected to the same video input via the internal video crosspoint router, otherwise, the wrong video input may be recorded. To avoid this restriction, use one of the other three JPEG codecs available in the system.

Tables 1-2 through 1-6, on pages 1-9 through 1-13, list the various video I/O configurations, as well as the locations of all the boards in the system. In the tables, note that factory installable option boards are shaded.

**Table 1-2. PDR202 and PDR204 Factory Standard Configurations with Installable Options**

Slot	PDR202A	PDR202D	PDR204A	PDR204D
J1	System CPU	System CPU	System CPU	System CPU
J2	Parallel Port	Parallel Port	Parallel Port	Parallel Port
J3				
J4	System SCSI	System SCSI	System SCSI	System SCSI
J5	Audio I/O Digital AES/EBU	Audio I/O Digital AES/EBU	Audio I/O Digital AES/EBU	Audio I/O Digital AES/EBU
J6	Video Mixer	Video Mixer	Video Mixer	Video Mixer
J7	Audio I/O Digital AES/EBU	Audio I/O Digital AES/EBU	Audio I/O Digital AES/EBU	Audio I/O Digital AES/EBU
J8	Video I/O Serial Digital Component	Video I/O Analog Composite	Video I/O Serial Digital Component	Video I/O Analog Composite
J9	Fibre Channel	Fibre Channel	Fibre Channel	Fibre Channel
J10	Disk Recorder Master	Disk Recorder Master	Disk Recorder Master	Disk Recorder Master
J11			Disk Recorder Slave	Disk Recorder Slave
J12	Video Out Picture Monitor (Analog) <i>or</i> Video Out Analog Composite	Video Out Picture Monitor (Analog) <i>or</i> Video Out Analog Composite	Video Out Picture Monitor (Analog) <i>or</i> Video Out Analog Composite	Video Out Picture Monitor (Analog) <i>or</i> Video Out Analog Composite
J13	Video In Analog Component	Video In Analog Component	Video In Analog Component	Video In Analog Component
J14	Video I/O Analog Composite	Video I/O Serial Digital Component	Video I/O Analog Composite	Video I/O Serial Digital Component
J15			Video I/O Analog Composite	Video I/O Serial Digital Component
J16	Reference / Timecode	Reference / Timecode	Reference / Timecode	Reference / Timecode
J17	Remote I/O RS422	Remote I/O RS422	Remote I/O RS422	Remote I/O RS422



**Table 1-3. PDR304 and PDR308 Factory Standard Configurations with Installable Options**

Slot	PDR304A	PDR304D	PDR308A	PDR308D
J1	System CPU	System CPU	System CPU	System CPU
J2	Parallel Port	Parallel Port	Parallel Port	Parallel Port
J3				
J4	System SCSI	System SCSI	System SCSI	System SCSI
J5	Audio I/O Digital AES/EBU	Audio I/O Digital AES/EBU	Audio I/O Digital AES/EBU	Audio I/O Digital AES/EBU
J6	Video Out Analog Composite	Video Out Picture Monitor (Analog)	Video Out Analog Composite	Video I/O Serial Digital Component
J7	Audio I/O Digital AES/EBU <i>or</i> Video Out Picture Monitor (Analog)	Audio I/O Digital AES/EBU <i>or</i> Video Out Picture Monitor (Analog)	Audio I/O Digital AES/EBU <i>or</i> Video Out Picture Monitor (Analog)	Audio I/O Digital AES/EBU <i>or</i> Video Out Picture Monitor (Analog)
J8	MPEG Video Decoder	MPEG Video Decoder	MPEG Video Decoder	MPEG Video Decoder
J9	Fibre Channel	Fibre Channel	Fibre Channel	Fibre Channel
J10	Disk Recorder Master	Disk Recorder Master	Disk Recorder Master	Disk Recorder Master
J11				
J12			MPEG Video Decoder	MPEG Video Decoder
J13	Video I/O Serial Digital Component		Video I/O Serial Digital Component	Video I/O Serial Digital Component
J14		Video I/O Serial Digital Component	Video I/O Analog Composite	Video I/O Serial Digital Component
J15		Video I/O Serial Digital Component	Video I/O Analog Composite	Video I/O Serial Digital Component
J16	Reference / Timecode	Reference / Timecode	Reference / Timecode	Reference / Timecode
J17	Remote I/O RS422	Remote I/O RS422	Remote I/O RS422	Remote I/O RS422

**Table 1-4. PDR312 and PDR316 Factory Standard Configurations with Installable Options**

Slot	PDR312A	PDR312D	PDR316A	PDR316D
J1	System CPU	System CPU	System CPU	System CPU
J2	Parallel Port	Parallel Port	Parallel Port	Parallel Port
J3				
J4	System SCSI	System SCSI	System SCSI	System SCSI
J5	Audio I/O Digital AES/EBU	Audio I/O Digital AES/EBU	Audio I/O Digital AES/EBU	Audio I/O Digital AES/EBU
J6	Video Mixer <i>or</i> Video Out Picture Monitor (Analog)	Video Mixer <i>or</i> Video Out Picture Monitor (Analog)	Video Out Analog Composite	Video Mixer <i>or</i> Video Out Picture Monitor (Analog)
J7	Audio I/O Digital AES/EBU <i>or</i> Video Out Picture Monitor (Analog)	Audio I/O Digital AES/EBU <i>or</i> Video Out Picture Monitor (Analog)	Audio I/O Digital AES/EBU <i>or</i> Video Out Picture Monitor (Analog)	Audio I/O Digital AES/EBU <i>or</i> Video Out Picture Monitor (Analog)
J8	MPEG Video Encoder/Decoder	MPEG Video Encoder/Decoder	MPEG Video Encoder/Decoder	MPEG Video Encoder/Decoder
J9	Fibre Channel	Fibre Channel	Fibre Channel	Fibre Channel
J10	Disk Recorder Master	Disk Recorder Master	Disk Recorder Master	Disk Recorder Master
J11	Disk Recorder Slave	Disk Recorder Slave	Disk Recorder Slave	Disk Recorder Slave
J12			MPEG Video Decoder	MPEG Video Decoder
J13	Video I/O Serial Digital Component		Video I/O Serial Digital Component	Video I/O Serial Digital Component
J14	Video I/O Analog Composite	Video I/O Serial Digital Component	Video I/O Analog Composite	Video I/O Serial Digital Component
J15				Video I/O Serial Digital Component
J16	Reference / Timecode	Reference / Timecode	Reference / Timecode	Reference / Timecode
J17	Remote I/O RS422	Remote I/O RS422	Remote I/O RS422	Remote I/O RS422



**Table 1-5. PDR324 Factory Standard Configurations with Installable Options**

Slot	PDR324A	PDR324D
J1	System CPU	System CPU
J2	Parallel Port	Parallel Port
J3		
J4	System SCSI	System SCSI
J5	Audio I/O Digital AES/EBU	Audio I/O Digital AES/EBU
J6	Video Mixer <i>or</i> Video Out Picture Monitor (Analog)	Video Mixer <i>or</i> Video Out Picture Monitor (Analog)
J7	Audio I/O Digital AES/EBU <i>or</i> Video Out Picture Monitor (Analog)	Audio I/O Digital AES/EBU <i>or</i> Video Out Picture Monitor (Analog)
J8	MPEG Video Encoder/Decoder	MPEG Video Encoder/Decoder
J9	Fibre Channel	Fibre Channel
J10	Disk Recorder Master	Disk Recorder Master
J11	Disk Recorder Slave	Disk Recorder Slave
J12	MPEG Video Encoder/Decoder	MPEG Video Encoder/Decoder
J13	Video I/O Serial Digital Component	
J14	Video I/O Analog Composite	Video I/O Serial Digital Component
J15	Video I/O Analog Composite	Video I/O Serial Digital Component
J16	Reference / Timecode	Reference / Timecode
J17	Remote I/O RS422	Remote I/O RS422



**Table 1-6. PDR404 Factory Standard Configurations with Installable Options**

Slot	PDR404A	PDR404D	PDR406A	PDR406D
J1	System CPU	System CPU	System CPU	System CPU
J2	Parallel Port	Parallel Port	Parallel Port	Parallel Port
J3				
J4	System SCSI	System SCSI	System SCSI	System SCSI
J5	Audio I/O Digital AES/EBU	Audio I/O Digital AES/EBU	Audio I/O Digital AES/EBU	Audio I/O Digital AES/EBU
J6	Video Mixer <i>or</i> Video Out Picture Monitor (Analog)	Video Mixer <i>or</i> Video Out Picture Monitor (Analog)	Video Mixer <i>or</i> Video Out Picture Monitor (Analog)	Video Mixer <i>or</i> Video Out Picture Monitor (Analog)
J7	Audio I/O Digital AES/EBU <i>or</i> Video Out Picture Monitor (Analog)	Audio I/O Digital AES/EBU <i>or</i> Video Out Picture Monitor (Analog)	Audio I/O Digital AES/EBU <i>or</i> Video Out Picture Monitor (Analog)	Audio I/O Digital AES/EBU <i>or</i> Video Out Picture Monitor (Analog)
J8	Disk Recorder Slave	Disk Recorder Slave	Disk Recorder Slave	Disk Recorder Slave
J9	Fibre Channel	Fibre Channel	Fibre Channel	Fibre Channel
J10	Disk Recorder Master	Disk Recorder Master	Disk Recorder Master	Disk Recorder Master
J11	DVCPRO Four-codec	DVCPRO Four-codec	DVCPRO Four-codec	DVCPRO Four-codec
J12	DVCPRO Two-codec	DVCPRO Two-codec	DVCPRO Two-codec	DVCPRO Two-codec
J13	Video I/O Analog Composite	Video I/O Serial Digital Component	Video I/O Analog Composite	Video I/O Serial Digital Component
J14	Video I/O Analog Composite	Video I/O Serial Digital Component	Video I/O Analog Composite	Video I/O Serial Digital Component
J15	Video I/O Analog Composite	Video I/O Serial Digital Component	Video I/O Analog Composite	Video I/O Serial Digital Component
J16	Reference / Timecode	Reference / Timecode	Reference / Timecode	Reference / Timecode
J17	Remote I/O RS422	Remote I/O RS422	Remote I/O RS422	Remote I/O RS422



## Configuration Labels

You may check/identify your configuration, including factory installed options, by looking at the bottom panel just below the rear panel board connectors. A configuration label, which identifies the board installed in the slot above the label, has been attached to assist you in making connections to your Profile system. Figure 1-3 shows the location of the configuration label.

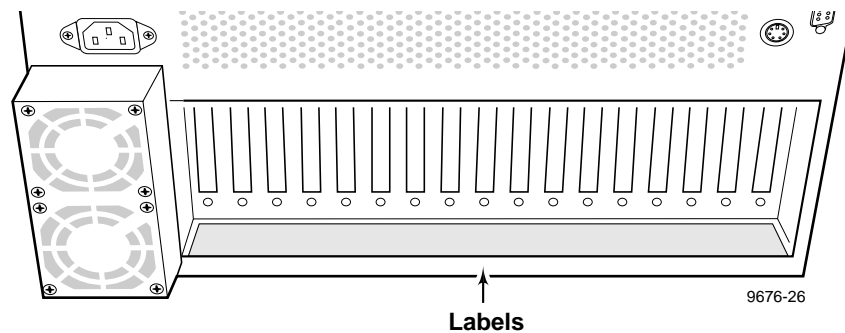

Figure 1-3. Configuration Labels Locations

## Maximum Video Data Rates

This section describes the maximum video data rate available per channel on the Profile Video File Server when all channels are in use. The maximum video data rate per channel depends on the Profile model, the type of storage, and the number of storage disk drives in the system. The Profile Video File Server can be configured with either RAID or non-RAID storage. Refer to Table 1-7, Table 1-8, and Table 1-9 to determine the maximum video data rates for various Profile models and storage options.

**Table 1-7. Maximum Video Data Rates Per Channel With Non-RAID Storage**

Profile Models with Non-RAID Storage	Maximum Video Data Rate Per Channel (When All Channels Are In Use)		
	3 Internal Drives	5 Internal Drives	8 Drives (Internal or PDX218)
PDR202	48Mb/s	48Mb/s	48Mb/s
PDR204	not available	48Mb/s	48Mb/s
PDR312	24Mb/s	50Mb/s	50Mb/s
PDR304	24Mb/s	50Mb/s	50Mb/s
PDR324	not available	24Mb/s	24Mb/s
PDR 316	not available	24Mb/s	24Mb/s
PDR308	not available	18Mb/s	24Mb/s

**Table 1-8. Maximum Video Data Rates Per Channel With PRS255 RAID Storage Chassis**

Profile Models with the PRS255 RAID Storage Chassis	Maximum Video Data Rate Per Channel (When All Channels Are In Use)			
	5 Drives	10 Drives	15 Drives	20 Drives
PDR202	24Mb/s	48Mb/s	48Mb/s	48Mb/s
PDR204	not allowed	36Mb/s	36Mb/s	48Mb/s
PDR312	24Mb/s	24Mb/s	24Mb/s	50Mb/s
PDR304	24Mb/s	24Mb/s	24Mb/s	24Mb/s

**Table 1-9. Maximum Video Data Rates Per Channel With PRS255M RAID Storage Chassis**

Profile Models with the PRS255M RAID Storage Chassis	Maximum Video Data Rate Per Channel (When All Channels Are In Use)		
	10 Drives	15 Drives	20 Drives
PDR312	50Mb/s	50Mb/s	50Mb/s
PDR304	24Mb/s	50Mb/s	50Mb/s
PDR324	24Mb/s	24Mb/s	24Mb/s
PDR 316	not allowed	24Mb/s	24Mb/s
PDR308	not allowed	18Mb/s	24Mb/s



You can select the video data rate the Profile system uses to record the video signal, unless you are using DVCPRO25 codecs which operate at a fixed 25Mb/s. When selecting video data rates, be sure not to exceed the total Profile system bandwidth. Fibre channel transfers, archive operations, and high bandwidth recording or playout may require that you reduce the data rate on other channels or operate fewer channels at one time. Although playout and recording take priority over other operations, exceeding your Profile system bandwidth may result in record or playback problems. For information on setting the video data rate in Profile applications software, refer to the appropriate sections of the *Profile Family User Manual*

## Storage Capacity Estimates

The Profile Video File Server storage capacity is determined by the number of disk drives in the system and the video data rate selected to record the video signal. The Profile Video File Server can be configured with three, five, or eight internal 18GB disk drives. You can refer to Table 1-10 for storage estimates based on the number of disk drives installed and the video data rate. All Profile applications allow you to select the video data rate used to record the video signal, unless you are using DVCPRO 25 compression which operates at a fixed 25Mb/s data rate, or DVCPRO 50 compression which operates at a fixed 50Mb/s data rate. For more information about setting the video data rate, refer the appropriate sections of the *Profile Family User Manual*.

Table 1-10. Profile Video File Server Storage Capacity Estimates

Number of Internal Drives	JPEG Factory Preset Data Rate Targets		MPEG-2 Factory Preset Data Rate Targets			DVCPRO 25 Data Rate	
	48Mb/s	24Mb/s	24Mb/s	15Mb/s	8Mb/s	25Mb/s	
	100KB/fld	50KB/fld	102KB/frm	66KB/frm	37KB/frm	120KB/frm	525/60
	120KB/fld	60KB/fld	123KB/frm	78KB/frm	41KB/frm	144KB/frm	625/50
3 disks	2 hrs	4 hrs	4 hrs	6.1 hrs	10.2 hrs	not available	
5 disks	3.5 hrs	6.5 hrs	6.5 hrs	10.2 hrs	17 hrs	not available	
8 disks	5.5 hrs	10.5 hrs	10.5 hrs	16.3 hrs	27.2 hrs	9	

Video storage times are estimates (within 10%) and include 2 audio channels and 1 timecode channel. Adding 2 more channels of audio adds approximately 1.5 Mb/s to the total data rate.

The Profile Video File Server storage space can be expanded by adding one or two PDX218 Disk Expansion Chassis containing eight 18GB disk drives each. You can refer to entries for eight drive systems in Table 1-10 to determine the storage capacity of a PDX218 at various video data rates.

**NOTE: Storage capacity estimates for the PRS255 RAID Storage Chassis are located in the PRS255 RAID Storage Instruction Manual.**

## **DVCPRO System Timing Considerations**

The DVCPRO codecs used in Profile systems are actually pairs of codecs. Because of this paired codec architecture, some restrictions apply to the DVCPRO codecs which require the following system timing limitations:

1. You must supply a Reference In signal to the Profile system.
2. All video signals that you want to record with a DVCPRO codec must be synchronous with the Reference In signal.
3. If you want to use the DVCPRO codecs as independent codecs, all of your video inputs must be auto-timed to the Reference input. In Configuration Manager, select Enable Auto-Timing for each input. You must ensure that each input actually auto-times by checking that the Auto-Timed indicator in the Video Input dialog box is lit. Refer to “Using the Profile Configuration Manager” in the *Profile Family User Manual* for more information on Auto-Timing.
4. If you are unable to auto-time an input, or if you wish to use the DVCPRO 25 codecs for BVW Insert/Edit operations, you may only use one of the codecs from each pair, DVCPRO25 #1, DVCPRO25 #3, and DVCPRO25 #5. Note that the second DVCPRO 25 codec from each pair must not be used.



---

## ***Mechanical Installation***

This chapter describes the mechanical installation of your Profile Video File Server into an equipment rack and the connection of cables to the rear panel. The chapter includes examples of connections to peripheral equipment such as the PDX218 storage expansion chassis, the PRS255 RAID Storage chassis. See the appropriate manuals for installation instructions for peripheral equipment. The information here covers:

- Mounting the Profile Video File Server in the rack.
- Mounting the RS-422 Connector Panel.
- Mounting the audio interface chassis (XLR216, BNC216, or PAC208/216).
- Making Profile Video File Server rear panel cable connections.
- Making other system connections.

### **Rack Mounting**

The equipment for the Profile Video File Server system installs in a standard 19-inch equipment rack. Rack slide tracks shipped with the Profile Video File Server and the Profile Audio Chassis allow them to slide in and out without having to remove them from the rack. However, if the rack does not already have rack slides installed, or if the slides are not correctly positioned, you will have to use those shipped with the Profile Video File Server.

When determining the location of the Profile Video File Server in the rack, bear in mind that the chassis with a full complement of disk drives weighs approximately 70 pounds. Observe the following warnings:



***WARNING: To prevent injury, two people are required to lift the Profile Video File Server. The Profile Video File Server is too heavy for one person to install in the rack.***



***WARNING: To prevent serious injury, insure that the rack is anchored to the floor so that it cannot tip over when the Profile Video File Server is extended out of the rack.***



## Mounting the Slide Tracks in the Rack

Figure 2-1 shows the components of a right-hand rack slide set. Note that the chassis sections are already attached to the Profile Video File Server and PAC208/216. When mounting rack slides in the equipment rack, bear the following in mind:

- The Profile Video File Server occupies 5 rack units (RUs).
- The PAC208/216 occupies 2 RUs

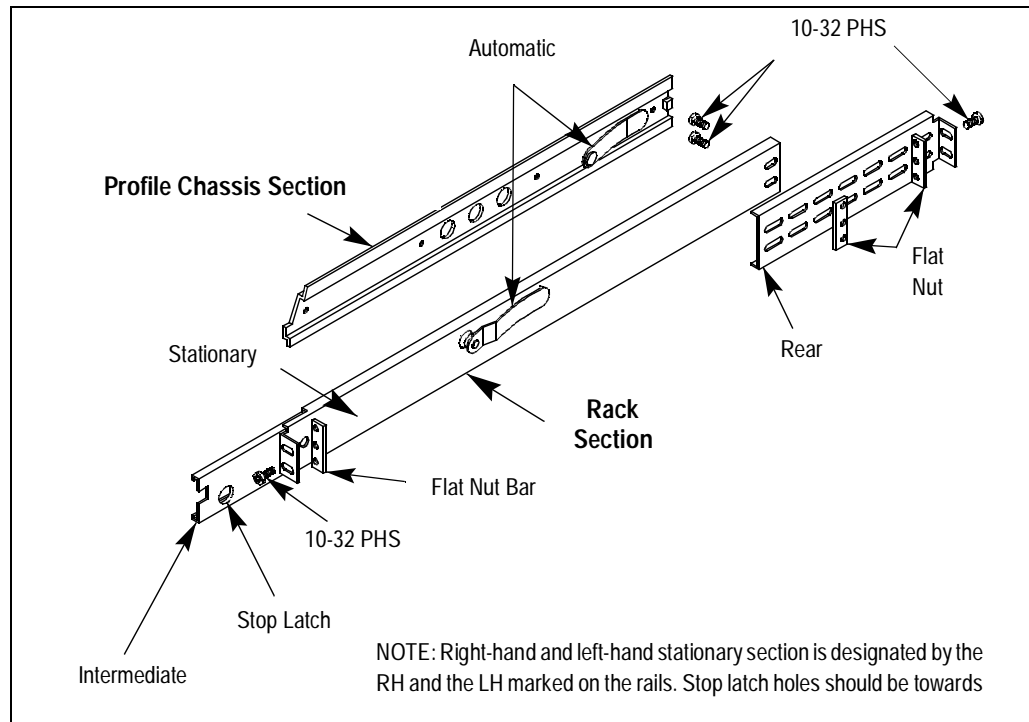

Figure 2-1. Rack Slide Set for Right Side of Profile Chassis and Rack



From Figure 2-2, choose the proper set of rail mounting holes on the rack. Notice that the hole spacing can vary with the rack type. When mounting the slides in racks with EIA spacing, make sure that the slides are attached to the 0.5-inch spaced holes.

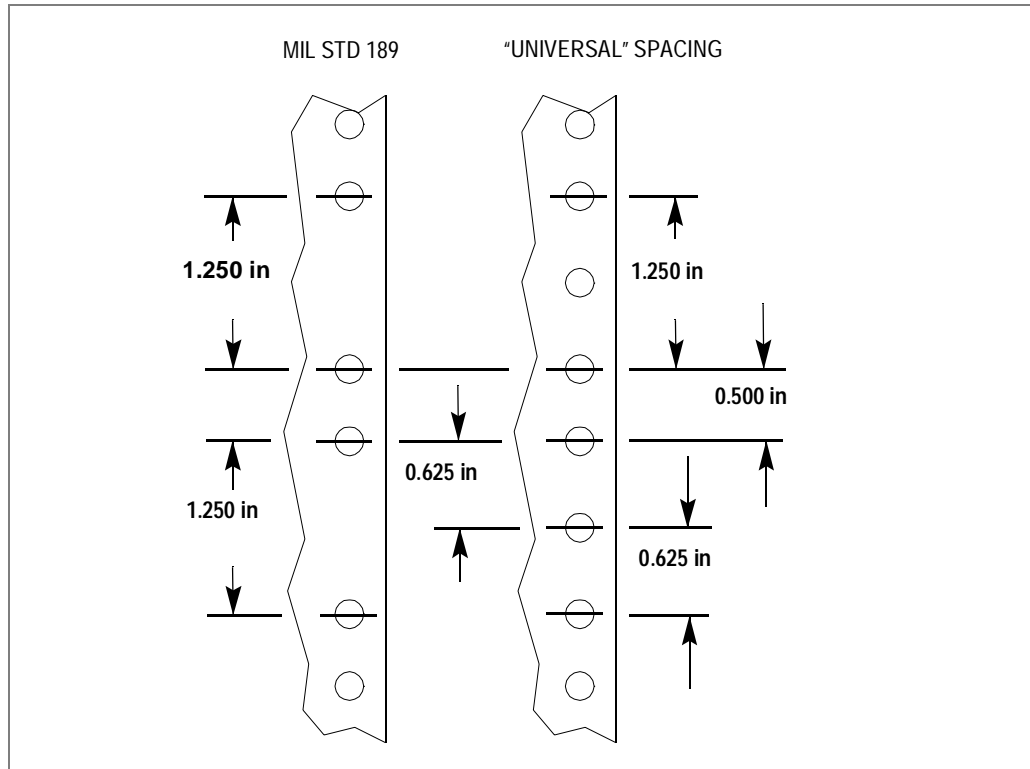

Figure 2-2. Spacing Specification for Mounting Holes in a Rack



Figure 2-3 and Figure 2-4 show front and rear rail mounting details for both deep and shallow racks. Mount the rails using the enclosed hardware. Make sure the stationary sections are horizontally aligned and are level, as well as parallel to each other.

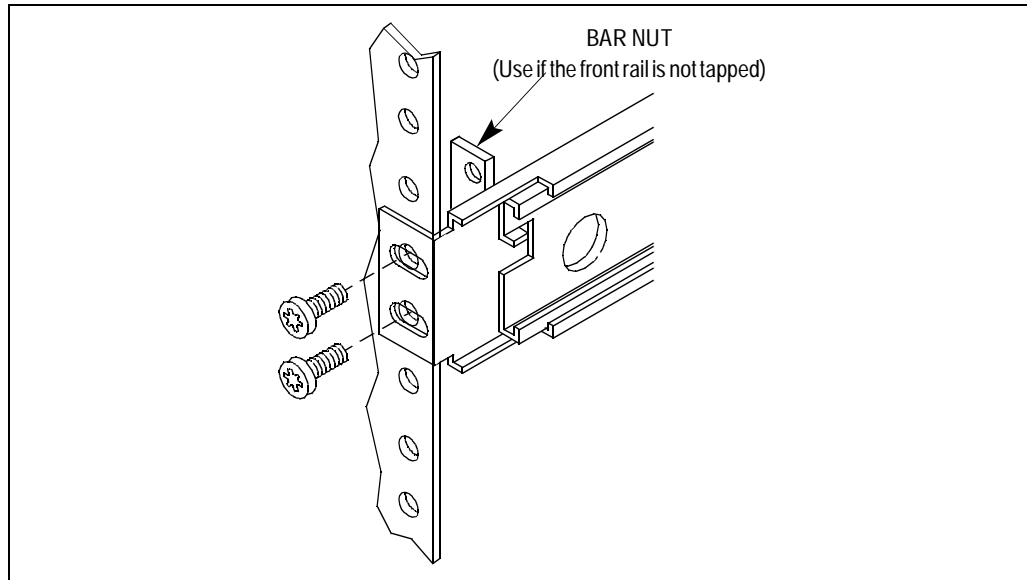

Figure 2-3. Front Rail Mounting Detail

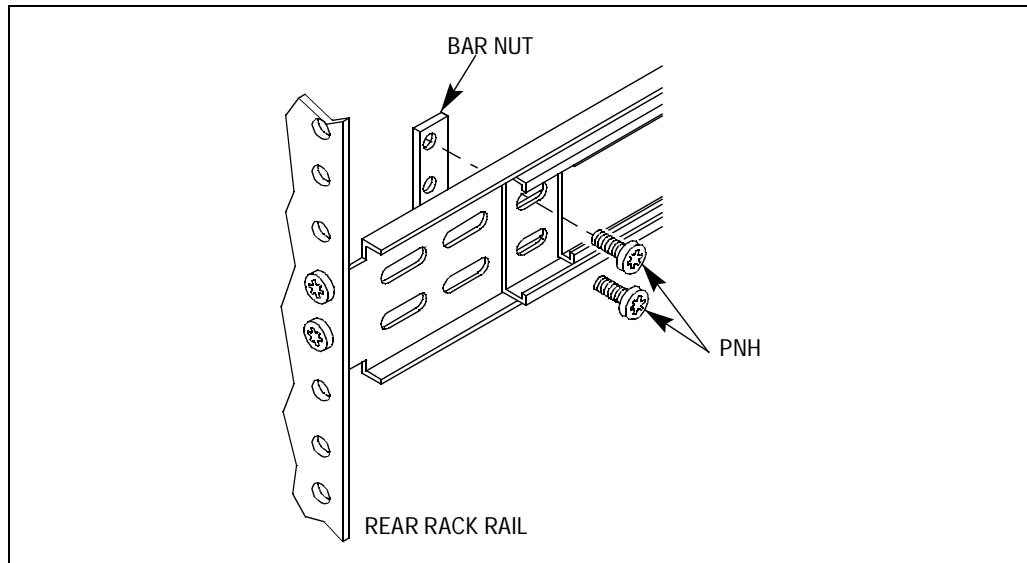

Figure 2-4. Rear Rail Mounting Detail

## Mounting the Profile Video File Server

In addition to room to make cable connections, the Profile Video File Server requires six inches (15.25 cm) of clearance behind the rear panel for connectors and cable bends. Insure adequate air flow around the chassis to provide sufficient cooling. (Operating ambient temperature will affect the amount of air circulation required to keep the Profile Video File Server within its temperature limitations.)

1. Pull the slide-out track section to the fully extended position. See Figure 2-5.



**WARNING:** To prevent injury, two people are required to lift the Profile Video File Server. It is too heavy for one person to install in the rack.



**WARNING:** To prevent serious injury, insure that the rack is anchored to the floor so that it cannot tip over when the Profile Video File Server is extended out of the rack.

2. Insert the ends of the chassis sections into the slide-out sections.
3. Push the chassis toward the rack until the chassis sections lock into the intermediate sections.
4. Press the stop latches in the intermediate sections and push the chassis toward the rack until the latches snap into their holes.

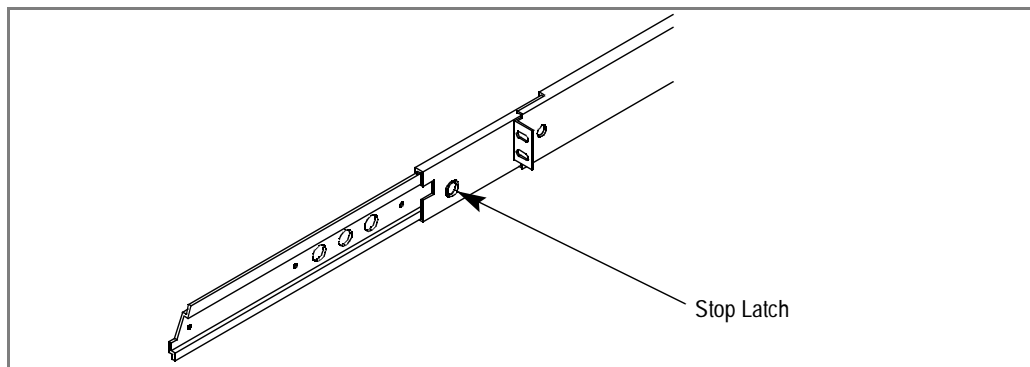

Figure 2-5. Rack Slide Stop Latch

5. Again, press the stop latches and push the cabinet fully into the rack.
6. Insert and tighten the front panel retaining screws.



## Making Rack Slide Adjustments

After installation, binding may occur if the slide tracks are not properly adjusted. To adjust the tracks:

1. Slide the chassis out approximately 10 inches.
2. Slightly loosen the mounting screws holding the tracks to the front of the rails and allow the tracks to seek an unbound position.
3. Tighten the mounting screws and check the tracks for smooth operation by sliding the chassis in and out of the rack several times.
4. Tighten the front panel retaining screws once the cabinet is in place within the rack to complete the installation.

## Mounting Panels and Audio Chassis

Refer to the information that follows when mounting panels and audio chassis:

- The RS-422 Connector Panel is 1 RU high with the mounting holes spaced 1.250 inches (3.175 cm) apart.
- The XLR216 is 2 RUs high with holes spaced 3.000 inches (7.62 cm) apart.
- The BNC216 is 1 RU high with holes spaced 3.000 inches (7.62 cm) apart.
- The PAC208 and PAC216 Audio Breakout panels are 2 RUs high with holes spaced 3.000 inches (7.62 cm) apart.

The RS-422, XLR216 and BNC216 panels mount at the back of the rack with four pan head screws. Ensure that there is room to make cable connections and mount in any order which allows connection to the PRO Series Video Disk Recorder.

## Making Rear Panel Connections

Because of the flexible configurations of the Profile Video File Server, not all of the rear panel connections described here may apply to your Profile system. The connections are described as though all factory installable options were in fact installed. As you go through these instructions, simply ignore a board you do not have installed. Note that any rear panel slot which does not have a board installed will have a blank cover over the rear panel slot.

***NOTE: Insure that power switches of all equipment to be installed are in the Off (O) positions.***

To insure compliance with EMI standards, all BNC cable connections require that an EMI suppression gasket be attached as shown in Figure 2-6. Your Profile system shipment included a set of gaskets.

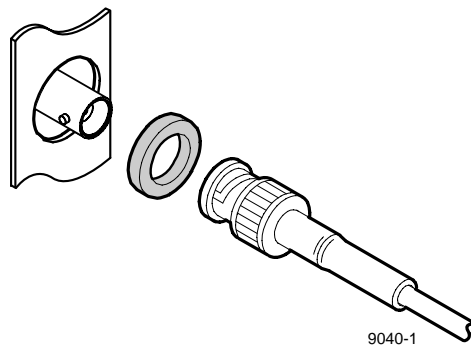

**Figure 2-6. BNC Connection With EMI Gasket**



## Connecting the Mouse and Keyboard

The Profile system mouse and keyboard connectors are located on the rear panel as shown in Figure 2-7.

Connect the mouse and keyboard as shown in Figure 2-7.

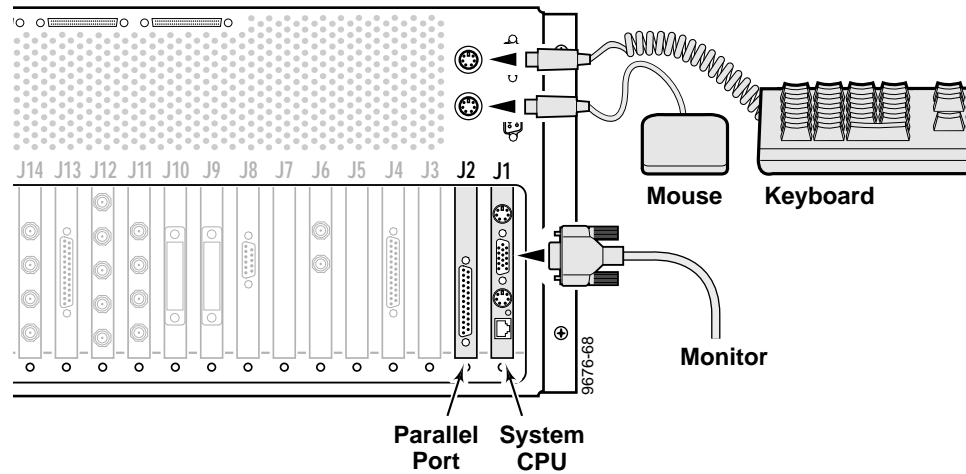

Figure 2-7. Mouse, Keyboard, and S-VGA Monitor Connections

## Connecting the Monitor

The S-VGA monitor connector is located on the System CPU board located in slot J1.

Connect the S-VGA Monitor cable to the 15-pin connector as shown in Figure 2-7.

## Connecting the Reference Genlock

The Profile Video File Server provides a Reference Genlock board, standard on all configurations, with two BNC connectors and a 25-pin DIN connector. The BNC connectors form a bridging, high impedance loop-through for the analog black burst house reference signal. This signal is used to synchronize the system video clock and provide frame reference. The 25-pin DIN provides Longitudinal Time Code interfaces, four in and four out. See Figure 2-8.

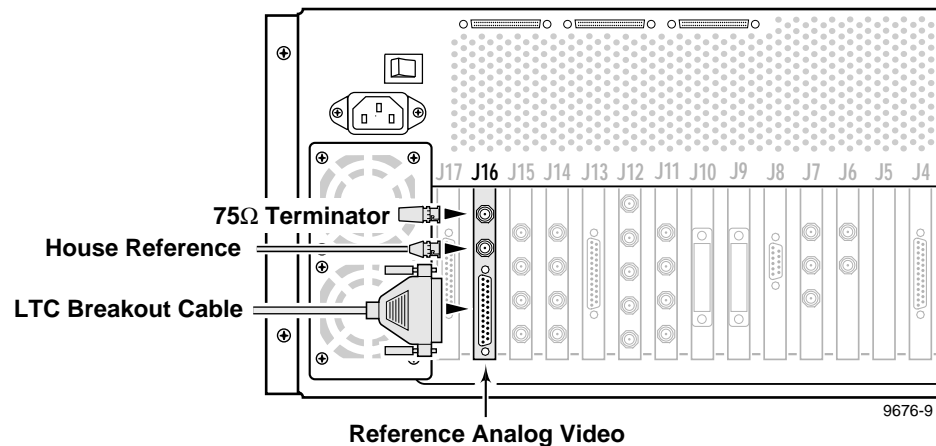

**Figure 2-8. Reference Genlock Cable Connections**

To make cable connections to the Reference Genlock board, refer to Figure 2-8 and:

1. Attach the optional Longitudinal Time Code breakout cable (Figure 2-9) to the 25-pin DIN connector.

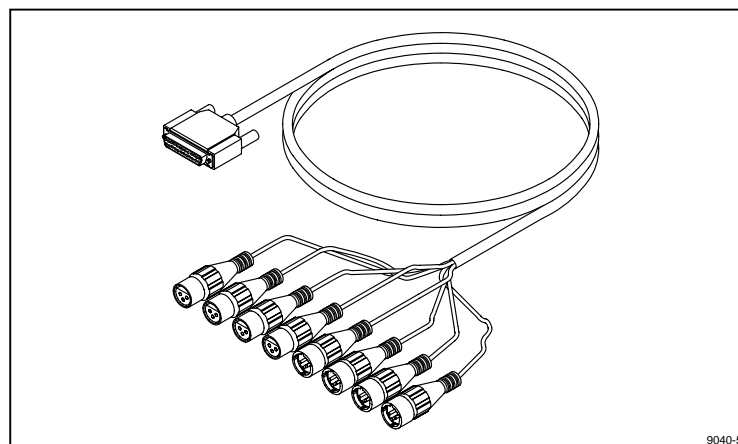

**Figure 2-9. Breakout Cable**

2. Place EMI gaskets on the BNC connectors as shown in Figure 2-6, page 2-7.
3. Attach the House Reference (Black Burst) BNC cable to the lower BNC connector.
4. Attach a 75Ω End-line Terminator to the upper BNC connector.



## Connecting Video

The Profile Video File Server supports Serial Digital I/O, Analog Composite I/O, and Analog Component Inputs. The video connections you make depends on your Profile Video File Server configuration.

### Connecting Serial Digital Video

The Profile Video File Server allows Serial Digital Video I/O board installations for two channels of serial digital input and output per board. Figure 2-10 shows serial digital cable connections for a typical location, slot J14. Refer to the rear panel labels or Tables 1-2 through 1-6 in Chapter 1, pages 1-9 through 1-13, to determine the slot location of this board in your system.

1. Place EMI gaskets on the four BNC connectors as shown in Figure 2-6, page 2-7.
2. Attach two BNC cables from serial digital sources to the IN A and IN B connectors.
3. Attach two BNC cables to serial digital sources to the OUT A and OUT B connectors.

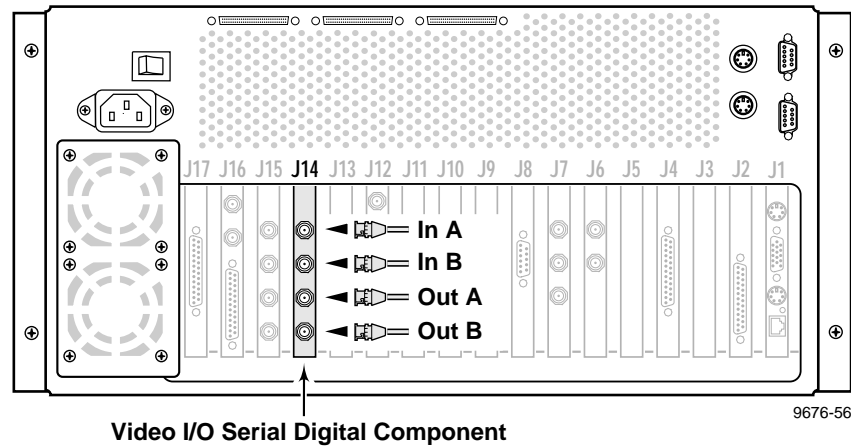

Figure 2-10. Serial Digital I/O Cable Connections



## Connecting Analog Composite Video I/O

The Profile Video File Server may include one or more an Analog Composite Video In/Output boards. Figure 2-11 shows analog composite video cable connections for a typical location, slot J14. Refer to the rear panel labels or Tables 1-2 through 1-6 in Chapter 1, pages 1-9 through 1-13, to determine the slot location of this board in your system.

The Analog Composite I/O board accepts two composite analog video inputs, and provides two composite analog video outputs. The board is also equipped with an S-Video connector, which allows video input to the Profile system directly from a source such as a video cassette recorder. However, the S-Video device takes the place of one of the inputs (either In A or In B). The board provides time base correction for any one input. If the Analog Composite Video I/O board is installed, refer to Figure 2-11 for an example and:

1. Place an EMI gasket on the BNC connectors being used as shown in Figure 2-6, page 2-7.
2. Connect analog composite input and output cables to the Analog Composite I/O board. See Figure 2-11 for an example.

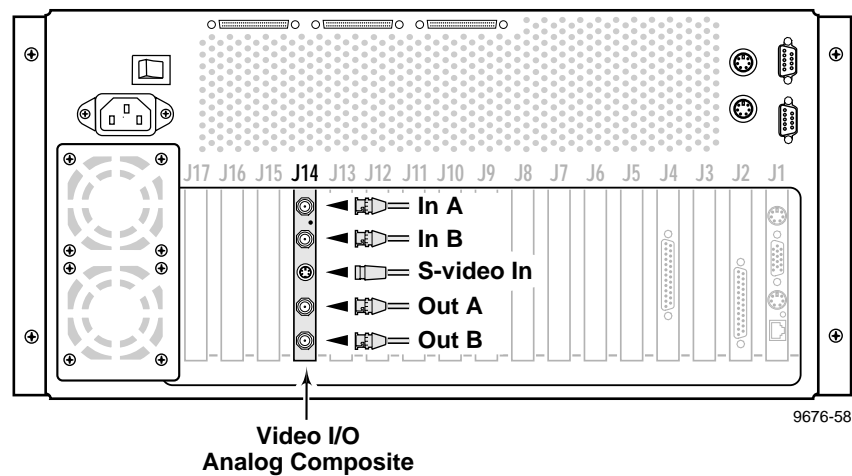

Figure 2-11. Analog Composite I/O Cable Connections



### Connecting Analog Composite Monitor

The Profile Video File Server may include an Analog Composite Monitor board which provides four channels of analog composite video output with time code burn-in and text overlay. With this board you can simultaneously display independent time code of each playback channel on a picture monitor display. Each channel also provides text overlay for source identification.

Figure 2-12 shows composite monitor cable connections for a typical location, slot J12. Refer to the rear panel labels or Tables 1-2 through 1-6 in Chapter 1, pages 1-9 through 1-13, to determine the slot location of this board in your system.

1. Place an EMI gasket on each BNC connector as shown in Figure 2-6, page 2-7.
2. Attach four BNC cables for composite video outputs to the OUT A, OUT B, OUT C, and OUT D connectors.

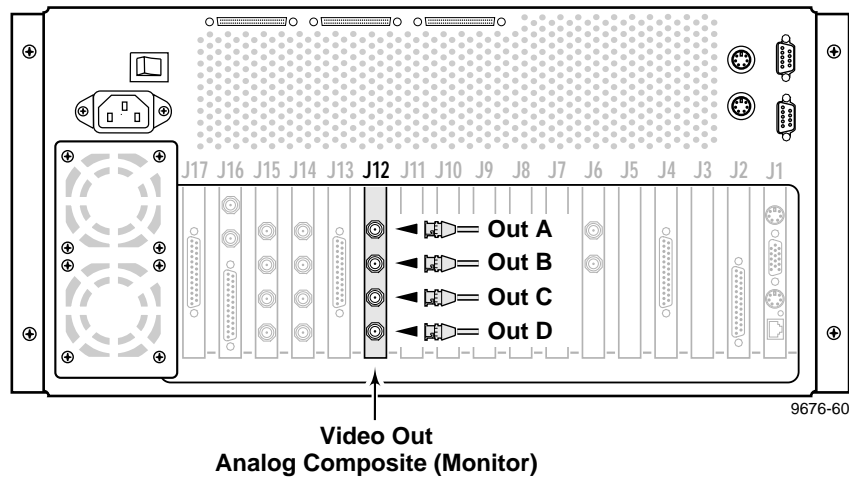

Figure 2-12. Analog Composite Monitor Cable Connections

## Connecting Analog Composite Video Out

The Profile Video File Server may include an Analog Composite Video Out board which provides up to four channels of analog composite video output. The board also has a Monitor D connector which is the Out D video with time code burn-in available.

Figure 2-13 shows analog composite video out cable connections for a typical location, slot J6. Refer to the rear panel labels or Tables 1-2 through 1-6 in Chapter 1, pages 1-9 through 1-13, to determine the slot location of this board in your system.

1. Place an EMI gasket on each BNC connector as shown in Figure 2-6, page 2-7.
2. Attach four BNC cables for composite video outputs to the OUT A, OUT B, OUT C, and OUT D connectors.
3. Attach a BNC cable for the Out D output with time code burned-in to the Monitor D connector (optional)

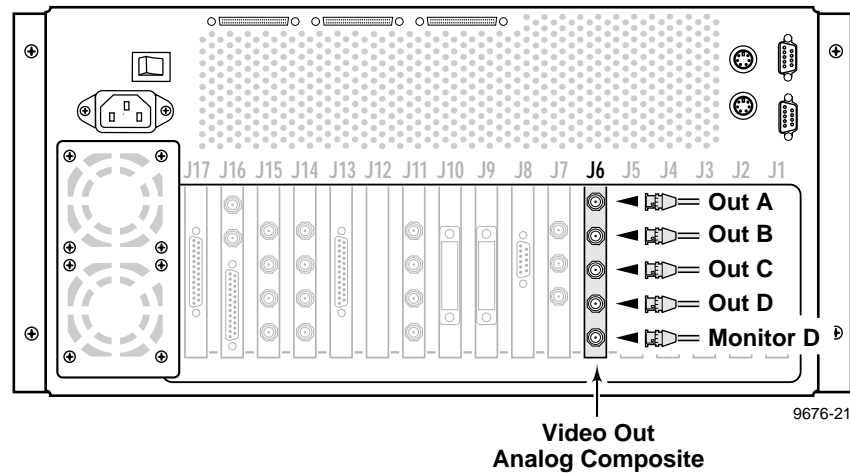

Figure 2-13. Analog Composite Out Cable Connections



## Connecting Component Analog Video

The Profile Video File Server may include an Component Analog Video In board which accepts a single source of component analog video input.

Figure 2-14 shows component analog video in cable connections for a typical location, slot J13. Refer to the rear panel labels or Tables 1-2 through 1-6 in Chapter 1, pages 1-9 through 1-13, to determine the slot location of this board in your system.

To make connections to the Analog Component Video In board, refer to the example in Figure 2-14 and:

1. Place an EMI gasket on the three BNC connectors as shown in Figure 2-6, page 2-7.
2. Attach three BNC cables from an appropriate component analog video source to the connectors.

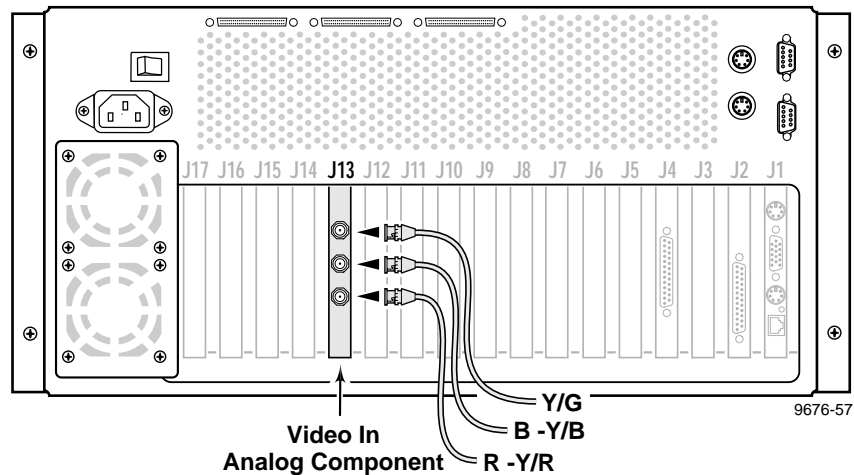

Figure 2-14. Analog Component Video In Cable Connections

## Connecting Audio

Your Profile Video File Server can have one or two Audio I/O boards installed. All units have at least one Audio I/O board, called Audio Signal Processor Board (or ASPB), which provides 16 channels of audio I/O. A second ASPB can be installed, adding 16 more channels for a total of 32 channels of audio I/O.

If you have two Audio I/O boards installed, the first one (or ASPB1) resides in the lowest numbered board slot and is labelled “AUDIO I/O IN/OUT CH 1-16”. The second ASPB (or ASPB2), if installed, is in the higher numbered board slot and is labelled “AUDIO I/O IN/OUT CH 17-32”. Refer to the rear panel labels or Tables 1-2 through 1-6 in Chapter 1, pages 1-9 through 1-13, to determine the slot location of these boards in your system.

The Audio Signal Processor Board (ASPB) can be configured to operate with analog, AES/EBU digital, and digital embedded (SMPTE 272M Level A) audio. If you are using only embedded audio, no interface chassis is required.

An interface chassis is required for Analog and AES/EBU Audio. Table 2-1 contains a summary of interface chassis available.

**NOTE:**

- *Interface chassis must be connected to both ASPBs for operation with 32 channels of analog or AES/EBU digital audio.*
- *To determine if the PAC200 Analog Audio Chassis is a PAC208 or PAC216, look at the identification tag toward the rear on the left side of the chassis.*

**Table 2-1. Audio Interface Chassis Summary**

PAC200 Chassis Models	Number of Analog Audio Channels	Number of AES/EBU Audio Channels	Comments
PAC208	8 (Ch 1 to 8)	8 (Ch 9 to 16)	ASPB audio channels 1 to 8 are always assigned to PAC208 analog channels 1 to 8. ASPB audio channels 9 to 16 are always assigned to PAC208 AES/EBU digital channels 9 to 16.
PAC216 (includes PACXLR breakout chassis)	16	16	The 16 ASPB audio channels are divided into four audio groups (4 channels each). You can assign the input for each audio group to either the analog or digital inputs of the PAC216. For example, the input to ASPB channels 1 to 4 can be assigned to analog input channels 1 to 4 or digital input channels 1 to 4 on the PAC216. The ASPB output channels 1 to 16 are always assigned to both analog and digital output channels 1 to 16 on the PAC216.
XLR216	none	16	Provides digital audio interface using XLR connectors.
BNC216	none	16	Provides digital audio interface using BNC connectors.



The 16 channels supported by the ASPB are divided into four audio groups with four audio channels in each group. The first group consists of channels 1 to 4. The second group consists of channels 5 to 8, and so on up to the fourth group.

Audio channels are typically assigned by groups to video channels. However, some Profile applications allow you to assign individual audio channels to video channels, provided you select the appropriate audio clock reference. See the Configuration Manager chapter of the *Profile Family User Manual* for more information about audio channel assignments.

See Appendix A, Table A-11 and Table A-12, for audio specifications.

### Connecting 16 Channels AES/EBU Digital Audio (XLR216 or BNC216)

Figure 2-15 shows ASPB connection to either an XLR216 audio panel or a BNC216 Audio panel for up to 16 channels (eight pairs) of AES/EBU digital only audio. AES/EBU digital audio sources are then connected to the XLR or BNC connectors on the panel.

Note the following on the XLR216 Audio Panel:

- Each pair of digital audio channels (1/2, 3/4... 15/16) has an In (top row on the panel) and an Out (bottom row).
- Connectors labelled “spares” are not available (not connected).
- The AES REF connector provides both a clock frequency and a framing alignment reference, generally from a master sync generator, to the incoming digital audio.
- The AES/EBU MONITOR connector allows monitoring of one of the eight pairs of digital audio channels selected through software (see the *Profile Family User Manual*). This is a digital audio output.

Note the following on the BNC216 Audio Panel:

- Each pair of digital audio channels (1/2, 3/4, etc.) has an In and an Out, side by side across the panel.
- The AES REF connector provides both a clock frequency and a framing alignment reference, generally from a master sync generator, to the incoming digital audio.
- The MON OUT connector allows monitoring of one of the eight pairs of digital audio channels selected through software (see the *Profile Family User Manual*). This is a digital audio output.

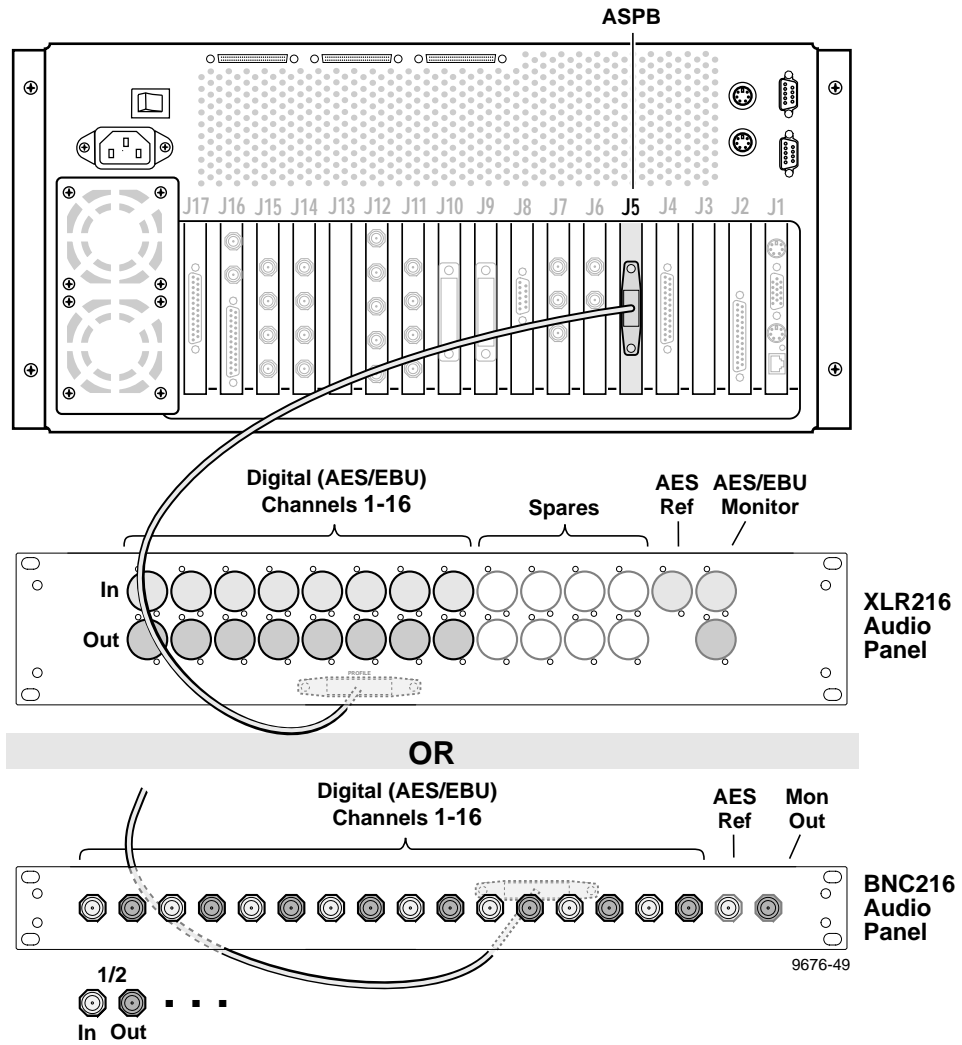

Figure 2-15. ASPB Connections for 16 Channels of AES/EBU Digital Audio



## Connecting 32 Channels AES/EBU Digital Audio (XLR216 or BNC216)

Figure 2-16 shows AES/EBU digital audio interface connections for a 32 audio channel Profile Video File Server. The 32 channel Profile system has two Audio I/O boards: ASPB1 and ASPB2. ASPB1 is in the lower numbered slot, and ASPB2 is in the higher numbered slot. Refer to the rear panel labels or Tables 1-2 through 1-6 in Chapter 1, pages 1-9 through 1-13, to determine the slot location of these boards in your system.

The 32 channel AES/EBU digital audio configuration uses two XLR216 Audio Panels or two BNC216 Audio Panels for up to 32 channels (sixteen pairs) of AES/EBU digital audio. AES/EBU digital audio sources are then connected to the XLR or BNC connectors on the panel.

Note the following on each XLR216 Audio Panel:

- The XLR216 connected to ASPB1 supports channels 1-16.
- The XLR216 connected to ASPB2 supports channels 17-32.
- Each pair of digital audio channels has an In (top row on the panel) and an Out (bottom row).
- Connectors labelled “spares” are not available (not connected).
- The AES REF connector on each XLR216 provides both a clock frequency and a framing alignment reference, generally from a master sync generator, to the incoming digital audio.
- The AES/EBU MONITOR connector on each XLR216 allows monitoring of one of the eight pairs of digital audio channels selected through software (see the *Profile Family User Manual*). This is a digital audio output.

Note the following on each BNC216 Audio Panel:

- The BNC216 connected to ASPB1 supports channels 1-16.
- The BNC216 connected to ASPB2 supports channels 17-32.
- Each pair of digital audio channels has an In and an Out, side by side across the panel.
- The AES REF connector provides both a clock frequency and a framing alignment reference, generally from a master sync generator, to the incoming digital audio.
- The MON OUT connector allows monitoring of one of the eight pairs of digital audio channels selected through software (see the *Profile Family User Manual*). This is a digital audio output.



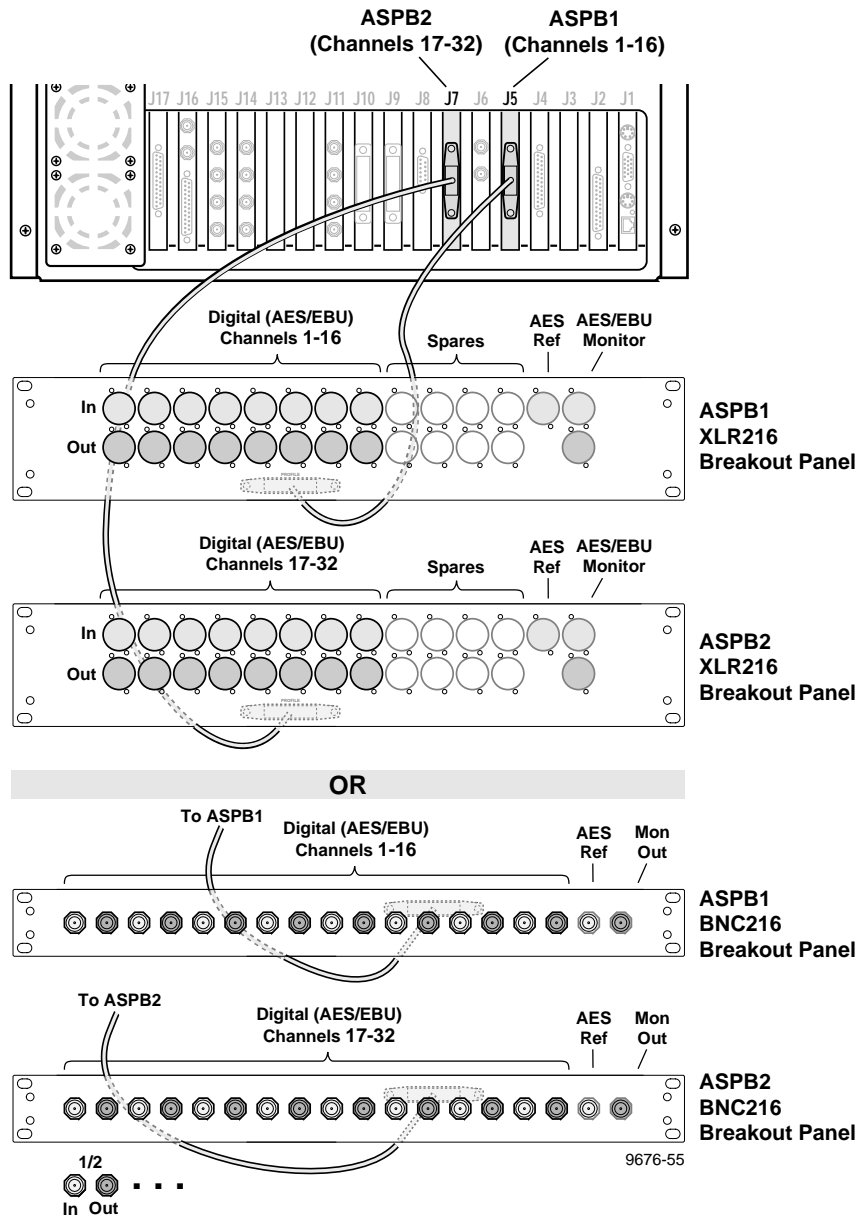

Figure 2-16. ASPB Connections for 32 Channels of AES/EBU Digital Audio



### Connecting 8 Analog and 8 Digital Channels (PAC208)

Figure 2-17 shows analog/digital audio connections for a 16 audio channel Profile Video File Server using the PAC208 version of the PAC200 Profile Audio Chassis. The PAC208 chassis allows you to connect eight analog and eight digital (four pairs) audio I/Os to the Profile Video File Server. ASPB audio channels 1 to 8 are always assigned to PAC208 analog channels 1 to 8. ASPB audio channels 9 to 16 are always assigned to PAC208 AES/EBU digital channels 9 to 16.

When used in this configuration, the PAC200 is labelled PAC208 on the left side panel at the rear of the panel.

***NOTE: When using analog audio, you must use Configuration Manager to enable analog audio inputs and to unmute analog audio outputs. See the Profile Family User Manual for Configuration Manager information.***

On the PAC200 (PAC 208):

- Connections are for analog audio channels 1-8, each with an In and Out.
- Connections are for four pairs of digital audio channels: 9/10, 11/12, 13/14, and 15/16, where each pair has an In and Out.
- The AES REF IN connector provides both a clock frequency and a framing alignment reference, generally from a master sync generator, to the incoming digital audio.
- The MONITOR LEFT/RIGHT connectors allow monitoring of one pair of audio selected through software (see the *Profile Family User Manual*). This is an analog output.

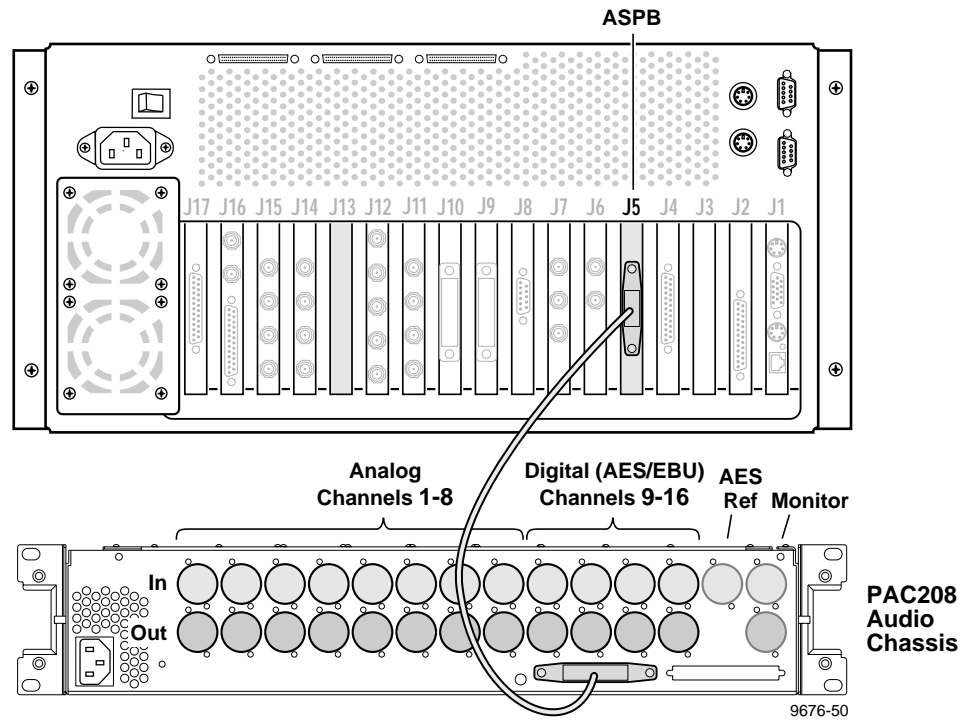

Figure 2-17. ASPB Connections for 8 Analog and 8 Digital Audio Channels



## Connecting 16 Analog/Digital Channels (PAC216)

Figure 2-18 shows analog/digital audio connections for a 16 audio channel Profile Video File Server using the PAC216 version of the PAC200 Profile Audio Chassis. This Profile system has one ASPB (Audio Signal Processor Board) which provides 16 channels of audio I/O. The PAC216 chassis and the PACXLR Audio Breakout Panel, allows you to connect up to 16 analog audio I/Os and 16 digital audio I/Os (eight pairs) to the Profile Video File Server.

The 16 ASPB audio channels are divided into four audio groups of four channels each. You can assign the input for each ASPB audio group to either the analog or digital input channels of the PAC216. For example, the input to ASPB channels 1 to 4 can be assigned to analog input channels 1 to 4 or digital input channels 1 to 4 on the PAC216. The four ASPB audio groups are always assigned to both analog and digital output channels on the PAC216.

When used in this configuration, the PAC200 is labelled PAC216 on the left side panel at the rear of the panel.

***NOTE: When using analog audio, you must use Configuration Manager to enable analog audio inputs and to unmute analog audio outputs. See the Profile Family User Manual for Configuration Manager information.***

On the PAC200 (PAC 216):

- Connections are for analog audio channels 1-8, each with an In and Out.
- Connections are for four pairs of digital audio channels: 9/10, 11/12, 13/14, and 15/16, where each pair has an In and Out.
- The AES REF IN connector provides both a clock frequency and a framing alignment reference, generally from a master sync generator, to the incoming digital audio.
- The MONITOR LEFT/RIGHT connectors allow monitoring of one pair of audio selected through software (see the *Profile Family User Manual*). This is an analog output.

On the PACXLR Breakout Panel:

- Connections are for analog audio channels 9-16, each with an In and Out.
- Connections are for four pairs of digital audio channels: 1/2, 3/4, 5/6, and 7/8 where each pair has an In and Out.

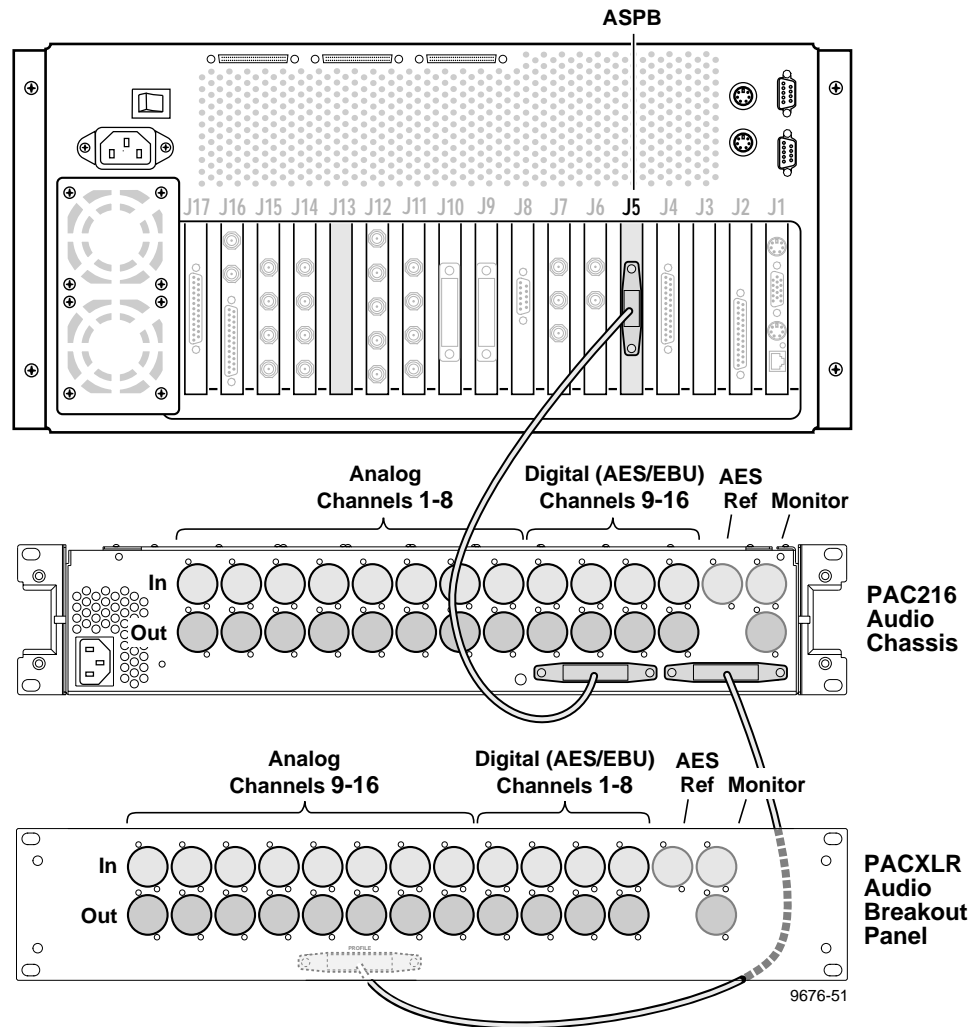

Figure 2-18. ASPB Connections for 16 Analog and 16 Digital Audio Channels



## Connecting 32 Analog/Digital Channels (PAC216)

Figure 2-19 shows analog/digital interface connections for a 32 audio channel Profile Video File Server. The 32 channel Profile system has two Audio I/O boards: ASPB1 and ASPB2. ASPB1 is in the lower numbered slot, and ASPB2 is in the higher numbered slot. Refer to the rear panel labels or Tables 1-2 through 1-6 in Chapter 1, pages 1-9 through 1-13, to determine the slot location of these boards in your system.

The 32 channel analog/digital audio configuration uses two PAC216 Profile Audio Chassis. Each PAC216 chassis and PACXLR Audio Breakout Panel allows you to connect up to 16 analog audio I/Os and 16 digital audio I/Os for a total of 32 analog audio and 32 of digital audio I/Os.

The 16 audio channels on each ASPB are divided into four audio groups of four channels each. You can assign the input for each ASPB audio group to either the analog or digital input channels of the PAC216. For example, the input to ASPB1 channels 1 to 4 can be assigned to analog input channels 1 to 4 or digital input channels 1 to 4 on the PAC216. The four ASPB audio groups are always assigned to both analog and digital output channels on the PAC216.

When used in this configuration, the PAC200s are labelled PAC216 on the left side panel at the rear of the panel.

**NOTE:** *When using analog audio, you must use Configuration Manager to enable analog audio inputs and to unmute analog audio outputs. See the Profile Family User Manual for Configuration Manager information.*

On the PAC200 (PAC216) connected to ASPB1:

- Connections on the chassis are provided for analog audio channels 1-8, each with an In and Out.
- Connections on the chassis are provided for four pairs of digital audio channels: 9/10, 11/12, 13/14, and 15/16, where each pair has an In and Out.
- Connections on the PAC XLR Audio Breakout Panel are provided for analog audio channels 9-16, each with an In and Out.
- Connections on the PAC XLR Audio Breakout Panel are provided for four pairs of digital audio channels: 1/2, 3/4, 5/6, and 7/8 where each pair has an In and Out.
- The AES REF IN connector provides both a clock frequency and a framing alignment reference, generally from a master sync generator, to the incoming digital audio.
- The MONITOR LEFT/RIGHT connectors allow monitoring of one pair of audio selected through software (see the *Profile Family User Manual*). This is an analog audio output.

On the PAC200 (PAC 216) connected to ASPB2:

- Connections on the chassis are provided for analog audio channels 17-24, each with an In and Out.
- Connections on the chassis are provided for four pairs of digital audio channels: 17/18, 19/20, 21/22, and 23/24 where each pair has an In and Out.

- Connections on the PAC XLR Audio Breakout Panel are provide for analog audio channels 25-32, each with an In and Out.
- Connections on the PAC XLR Audio Breakout Panel are for four pairs of digital audio channels: 25/26, 27/28, 29/30, and 31/32 where each pair has an In and Out.
- The AES REF IN connector provides both a clock frequency and a framing alignment reference, generally from a master sync generator, to the incoming digital audio.
- The MONITOR LEFT/RIGHT connectors allow monitoring of one pair of audio selected through software (see the *Profile Family User Manual*). This is an analog output.

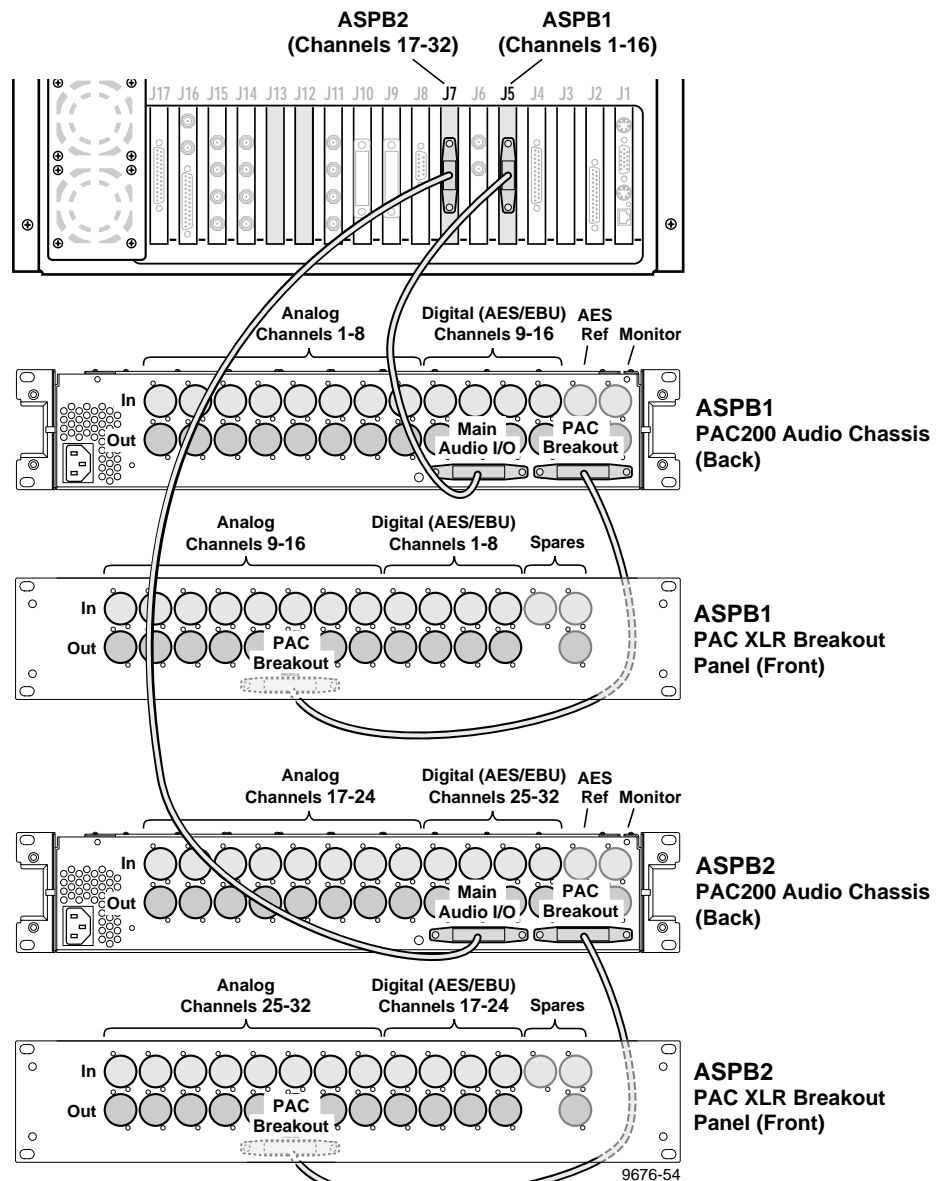

Figure 2-19. ASPB Connections for 32 Analog and 32 Digital Audio Channels



## Connecting SCSI Devices

The Profile Video File Server has a number of connectors for attaching SCSI devices. There are SCSI connectors on the Master and Slave Enhanced Disk Recorder boards, on the System SCSI board, and along the top of the rear panel (see Figure 2-20). Beyond the Master Enhanced Disk Recorder board, standard on all configurations, the number of SCSI connectors available depends on your configuration. Also, the actual board locations may vary. Refer to the rear panel labels or Tables 1-2 through 1-6 in Chapter 1, pages 1-9 through 1-13, to determine the slot location of these boards in your system.

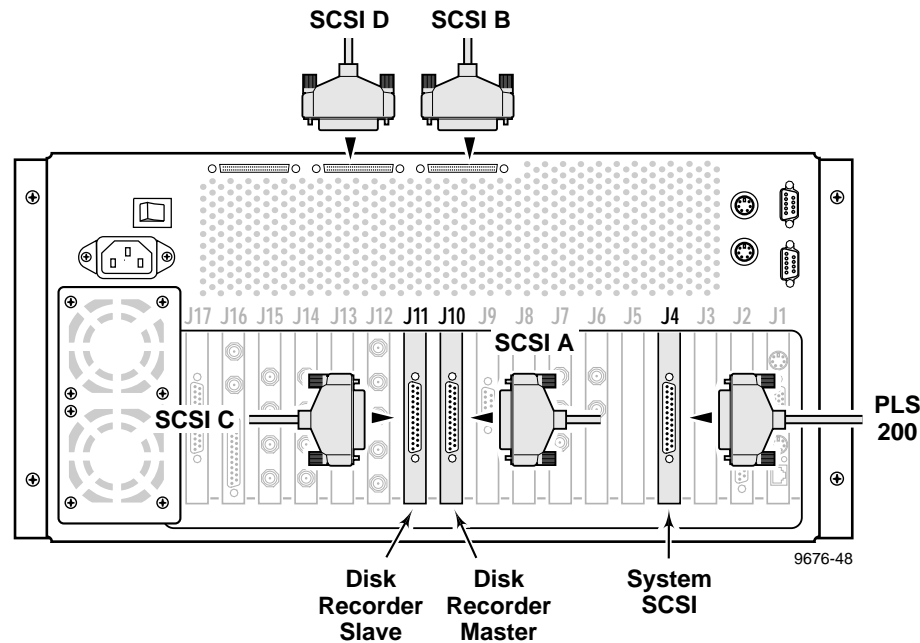

Figure 2-20. SCSI Cable Connections

The Master Enhanced Disk Recorder board, shown in Figure 2-20, provides a SCSI A bus and a SCSI B bus. (The SCSI B bus is **not** present on Profile Video File Servers which have eight internal media disks, and no Slave Enhanced Disk Recorder board.) Connect disk-based SCSI devices such as the PDX 218 Disk Expansion chassis to the SCSI A bus connector on the board at the rear panel. Connect tape-based SCSI devices such as the PLS 200 Profile Library System to the SCSI B bus connector at the top of the rear panel.

If installed, the Slave Enhanced Disk Recorder board provides a SCSI C bus and a SCSI D bus (see Figure 2-20). Connect disk-based SCSI devices to the SCSI C bus connector on the board at the rear panel. Connect tape-based SCSI devices such as the PLS 200 Profile Library System to the SCSI D bus connector at the top of the rear panel.

The System SCSI board, shown here in slot J4 (see Figure 2-20) is installed as part of the optional Profile Library System. If installed, connect the cable from the Profile Library System to this board. (See the *PLS 200 Installation Manual* for details about installing the PLS 200.) Note that the System SCSI board is only used with the PLS 200 and the Ampex DST412 at this time.



**NOTE:** Disk-based SCSI storage devices attached to the Profile Video File Server, such as the PDX218 or PRS250, must be configured using the Profile Disk Utility before they can be used as part of the system. See “Using the Profile Disk Utility” in the Profile Family User Manual.

See Figure 2-21 through Figure 2-25 for examples of Grass Valley Group SCSI devices that can be connected to the SCSI connectors on the Master and Slave EDR boards.

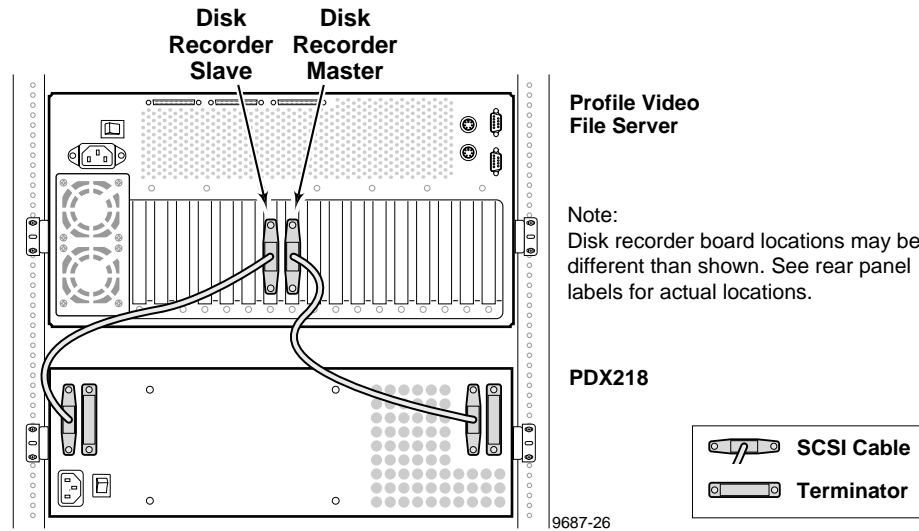

**Figure 2-21. Example 1: Connecting a PDX218 Disk Expansion Chassis**

Example 1 (Figure 2-21) shows disk expansion of a Profile system equipped with Master and Slave EDR boards. In this example, the PDX218 Disk Expansion chassis provides four hard disk drives to the SCSI A bus of the Master EDR and four hard disk drives to the SCSI C bus of the Slave EDR.

**NOTE:** This example requires attachment of SCSI Terminators to the unused SCSI connectors on the PDX 218 as shown in Figure 2-21.

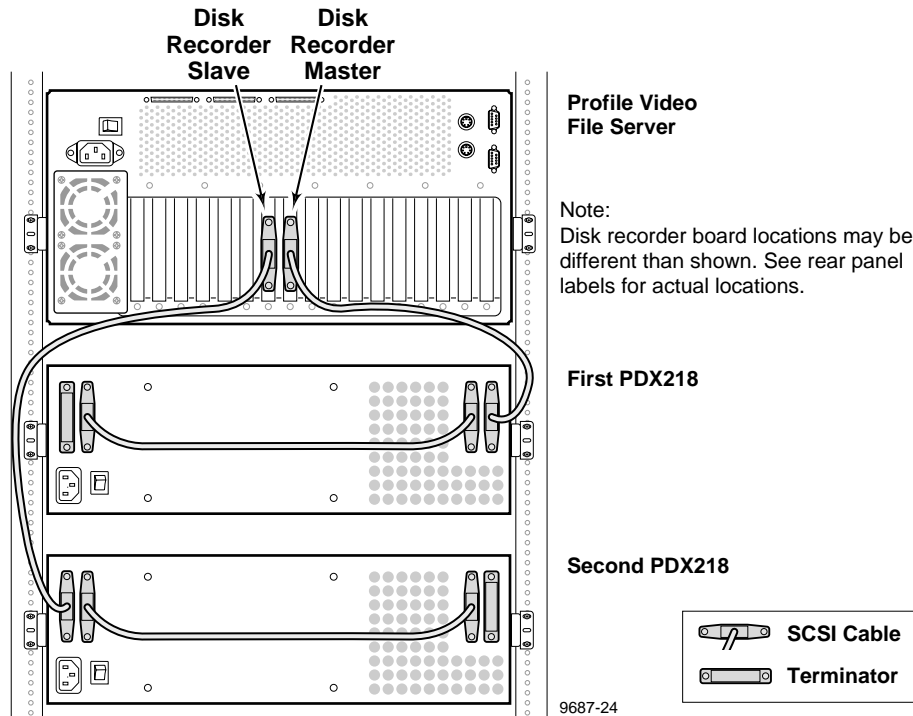

**Figure 2-22. Example 2: Connecting two PDX218 Disk Expansion Chassis**

Example 2 (Figure 2-22) shows disk expansion of a Profile system equipped with Master and Slave EDR boards. In this example, two PDX218 Disk Expansion chassis are used. One PDX218 provides eight hard disk drives to the SCSI A bus of the Master EDR and the other PDX218 provides eight hard disk drives to the SCSI C bus of the Slave EDR.

**NOTE:** This example requires attachment of SCSI Terminators to the unused SCSI connectors on each PDX 218 as shown in Figure 2-22.

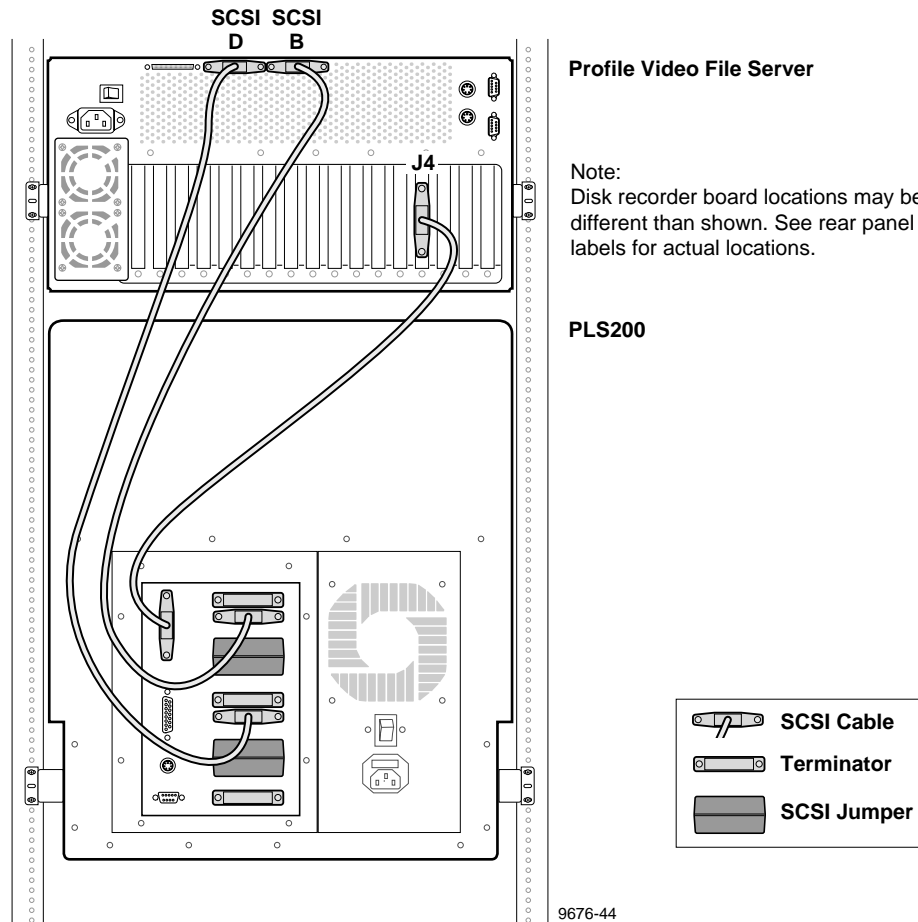

**Figure 2-23. Example 3: Profile Video File Server to PLS 200 Connections**

Example 3 (Figure 2-23) shows connection of a Profile Library System (PLS 200) to a Profile Video File Server equipped with a Slave EDR. This example allows archiving material on the Profile Video File Server to the PLS 200 through the SCSI B and SCSI D buses. The System SCSI board at Profile Video File Server Slot J4 provides control signal for the library robot.

**NOTE:** This example requires attachment of SCSI Terminators on the PLS 200 as shown in Figure 2-23.

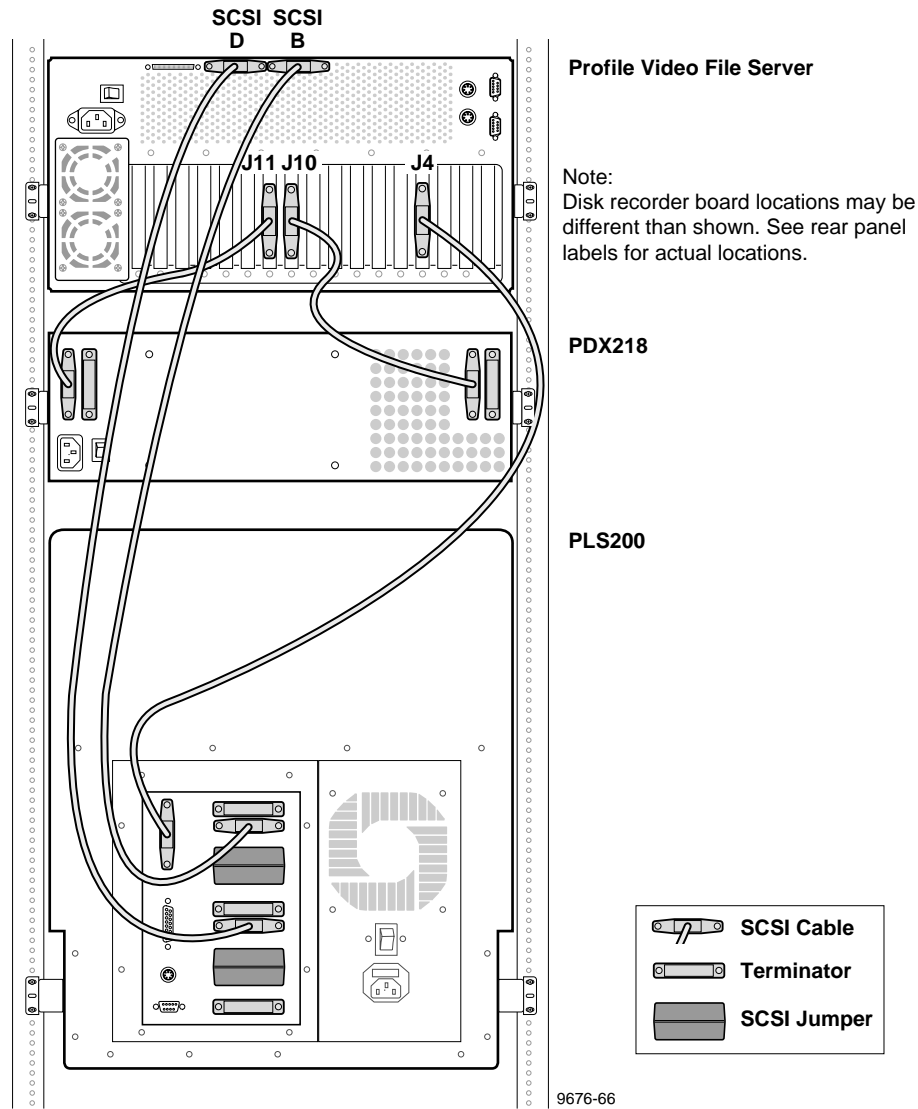
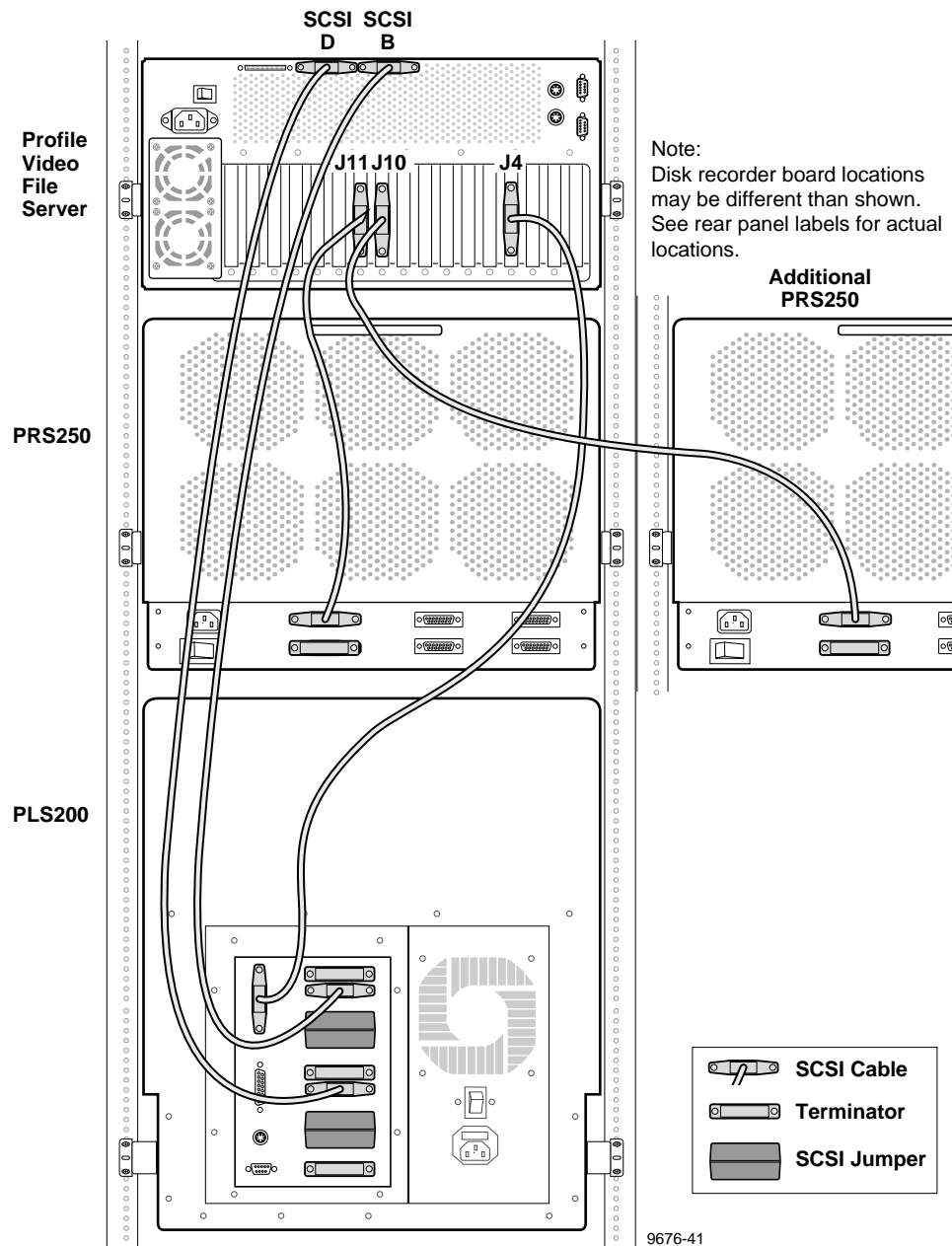

Figure 2-24. Example 4: Profile Video File Server to PDX 218 and PLS 200 Connections

Example 4 (Figure 2-24) shows disk expansion of a Slave EDR-equipped Profile system and connection to a Profile Library System (PLS200). This example combines Examples 1 and 2. Note that cabling from the PLS200 connects to the SCSI B and SCSI D buses on the Profile Video File Server, and the PDX218 connects to the SCSI A and SCSI C buses on the Profile Video File Server.

**NOTE:** This example requires attachment of SCSI Terminators on the PLS200 and the PDX218 as shown in Figure 2-24.



**Figure 2-25. Example 5: Profile Video File Server to Multiple RAIDs and PLS 200 Connections**

Example 5 (Figure 2-25) shows connection of the Profile Video File Server to two RAID Storage chassis (PRS250) and to a Profile Library System (PLS200). In this example, cabling connects the SCSI A bus to one PRS250 and the SCSI C bus to another PRS250. (You can connect PRS200/A units in a similar fashion.) The PLS200 is connected to the SCSI B and SCSI D buses on the Profile Video File Server.

**NOTE:** This example requires attachment of SCSI Terminators on the PLS200 and on the PRS250s, as shown in Figure 2-25.



## Connecting RS-422 Devices

The Profile Video File Server provides eight RS-422 interface ports through a single connector on the RS-422 Interface board. Attaching the RS-422 Connector Panel to the RS-422 interface board provides eight standard DB9 RS-422 connectors as shown in Figure 2-26.

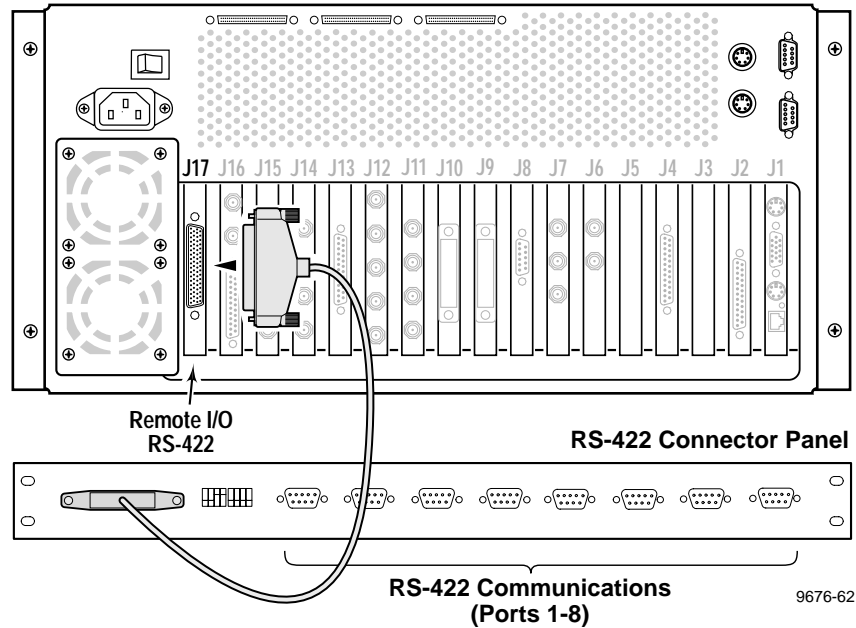
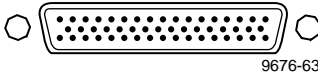
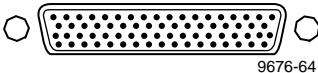

Figure 2-26. Profile Video File Server and RS-422 Connector Panel Cable Connection

On some Profile systems, the RS-422 Interface board connector may not appear as shown in Figure 2-26. Be sure to use the cable shipped with your system. Table 2-2 shows the two connectors and the cable part numbers used.

Table 2-2. RS-422 Interface Board Connector

RS-422 Board Connector	Part Number of Cable Used
	174-3507-XX
	174-4198-XX

The DIP switch on the RS-422 Connector Panel includes a switch for each RS-422 port P1 to P8. Setting a switch to DEVICE indicates the port is being used by external equipment to control the Profile system. Setting a switch to CONTROLLER indicates software running on the Profile system is using the port to control external equipment.

## **Connecting Network Devices**

The Profile Video File Server supports connection to Ethernet and Fibre Channel networks.

### **Connecting Fibre Channel**

If the Fibre Channel board is installed, there are a number of ways it may be connected for networking. Profile Video Networking requires both a Fibre Channel network and an Ethernet network. See Chapter 4, “Networking Your Profile System”, for Fibre Channel connection information.

### **Connecting to Ethernet**

The Profile Video File Server provides a standard RJ45 connector on the System CPU board for connecting to 10/100BASE-T Ethernet networks. See Chapter 4, “Networking Your Profile System”, for more Ethernet connection information.



## Making Power Connections

### Power Source

The Profile Video File Server and PAC208/216 operate from a single-phase power source having one of its current-carrying conductors at or near earth ground (the neutral conductor). Only the line conductor is fused for over-current protection. Grass Valley Group does not recommend connection to systems that have both current carrying conductors live with respect to ground as power sources, such as phase-to-phase in multi-phase systems.



### Source Power Frequency and Voltage Ranges

The Profile Video File Server and PAC 208/216 operate at line frequencies of 50 or 60 Hz at nominal voltages from 100 to 240 VAC. Table 2-3 lists the power cord options available. Figure 2-27 shows the location of the Profile Video File Server power cord connector (just below the main power switch).

Insure that the power switches of all equipment are set Off. Attach all power cords from the equipment to the appropriate power sources.

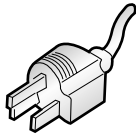

**Table 2-3. Power Cords for the Profile Video File Server and PAC 208**

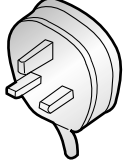
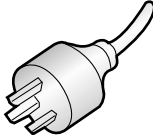
Power Plug	Description
	Standard 120 V, 3-prong power plug on a 2.5 meter long power cord. For use with common ground systems in North America.
	Universal European 230V/10A power plug on a 2.5 meter long power cord.
	United Kingdom 230V/10A power plug on a 2.5 meter long power cord.
	Australian 230V/10A power plug on a 2.5 meter long power cord.

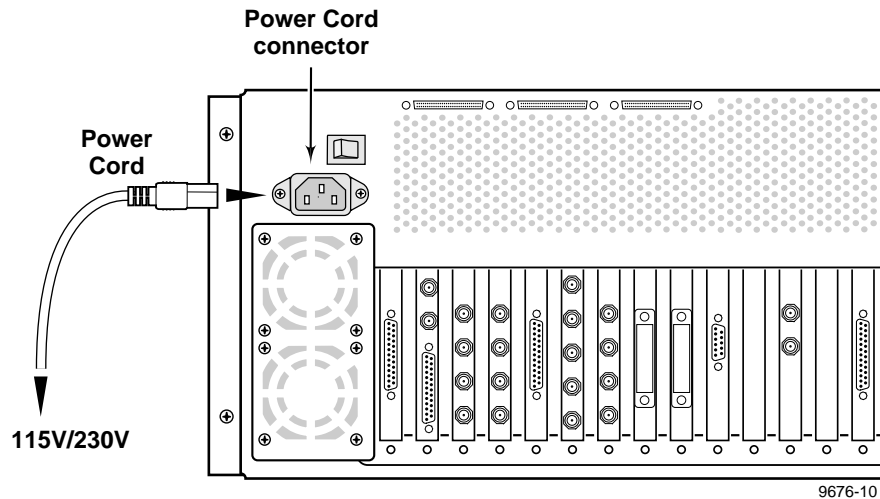

**Figure 2-27. Power Cord Connector**

This completes the mechanical installation of the Profile Video File Server. Continue with Chapter 3, “Starting Your Profile System”.



---

# Starting Your Profile System

This chapter contains information to get you up and running with your Profile Video File Server. The tasks you will perform are:

- Turning Profile system and peripheral equipment On.
- Logging On
- Configuring your Profile system.
- Updating your Emergency Repair Disk.

This chapter also includes a brief verification test and troubleshooting information.

## Power On/Off

This heading describes how to turn on the power to the Profile System and peripheral equipment. Before you turn on the power you need know about logging on to the Profile system.

## Logging On

When the Profile system power is turned on and before Windows NT boots, you must make a choice of how you want to logon the system.

## Automatic Logon

When the Profile system is powered on you may let Windows NT go through an automatic logon sequence. The system will perform automatic logon using a default account called *profile*. After automatic logon, the Profile VdrPanel application will appear as shown in Figure 3-3.

Automatic logon will occur at power On when:

- The *profile* account was used the last time the Profile Video File Server was turned off.
- The Profile Video File Server is initially powered On from the factory. (The factory sets the last user to *profile* prior to shipment.)



## Logon as Administrator

When the Profile system is powered On, you may interrupt automatic logon and logon as Administrator. It is not necessary to logon as administrator to configure Profile System software. However, you must logon as Administrator for Windows NT administration and to:

- Configure Ethernet network settings (see Chapter 4, “Networking Your Profile System”).
- Install new software applications or upgrades (see *Profile Release Notes*).

To logon as Administrator:

1. Power-on the Profile system, then hold the Shift key down during start-up to prevent auto-logon as *profile*. Be sure to continue holding the shift key until the logon dialog box appears.
2. Logon as *administrator*. The default *administrator* password on a Profile system is *triton*.

The next time the Profile system is restarted, Windows NT will display a logon error message. When this occurs, use the logon dialog box to logon manually as *administrator* or as *profile* (see the following procedure).

## Logon as Profile

After performing system administrative tasks using the *administrator* user account, you must logon using the *profile* account to enable the automatic logon feature for future system boots.

To logon as *profile*:

1. Power up or log off the Profile System.
2. When the logon error message appears click **OK**.
3. When the dialog box appears, logon as *profile*. The factory default password for *profile* is *profile*.

Windows NT will now perform automatic logon the next time the system is restarted.

## Turning Power On

Figure 3-1 shows the location on the rear panel of the main power switch which connects main power to the unit. Figure 3-2 shows the location of front panel power switch which provides system On/Off control.

To turn the Profile system power On:

1. Turn the power On to all system peripheral equipment.
2. If appropriate, turn PLS 200 power On.
3. If appropriate, turn PRS 250 power On and turn On the power to any other external SCSI devices.
4. As appropriate, turn PDX 218 and PAC 208/216 power On.

5. Wait approximately 1 to 2 minutes.
6. On the rear panel of the Profile Video File Server (see Figure 3-1), turn the main power switch to I (On).
7. On the front panel of the Profile Video File Server (see Figure 3-2), turn the power switch to On.

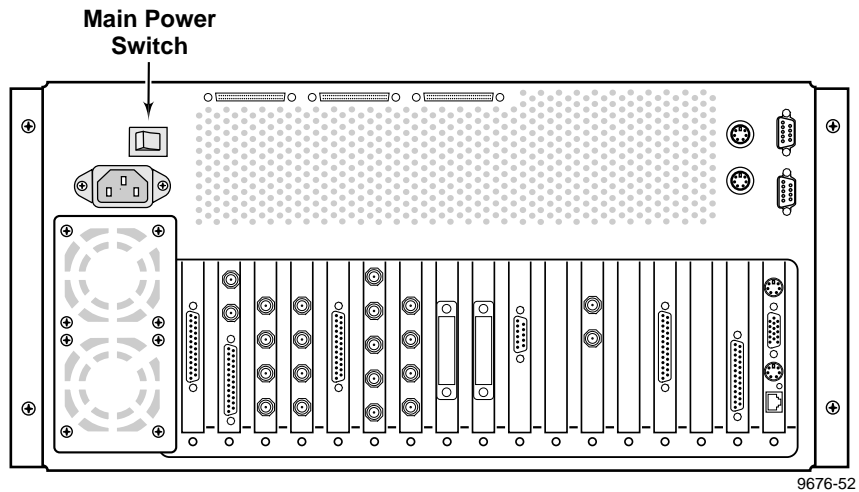

Figure 3-1. Rear Panel Main Power Switch

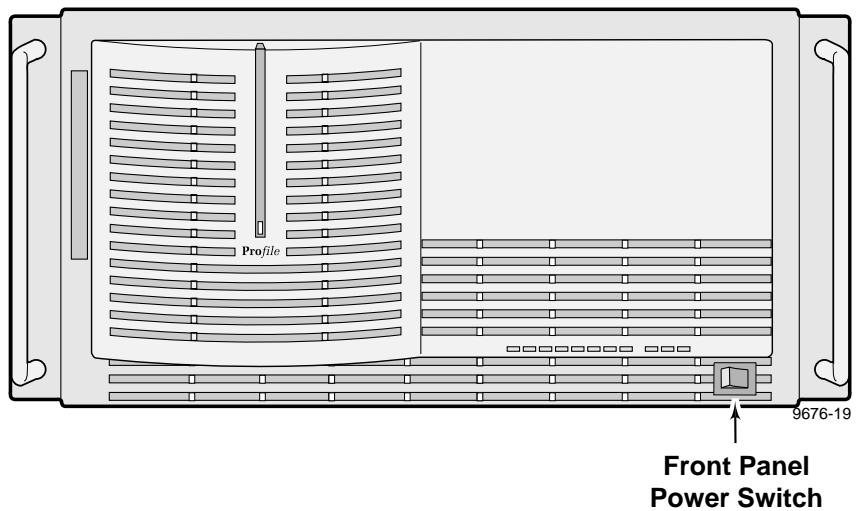

Figure 3-2. Front Panel Power Switch



## Turning Power Off

To turn your Profile system Off without loss of data, you must:

1. Quit all Profile System Software by selecting **Quit** or **Exit** from the File menu.
2. Exit or Quit any other processes which may be running in the same way.
3. Shutdown Windows NT by pressing the CTRL+ALT+DEL key sequence and choosing **Shutdown**.
4. When Windows NT displays a message that it is safe to turn off the system, turn the front panel power switch to **Standby** and then the rear panel main power switch to **O** (Off).

## System Set-up

If you have not interrupted the automatic logon sequence (see “Logging On” on page 3-1), your Profile system will go through its normal self-check and initialization sequence. When completed, the VdrPanel, shown in Figure 3-3, appears on the monitor.

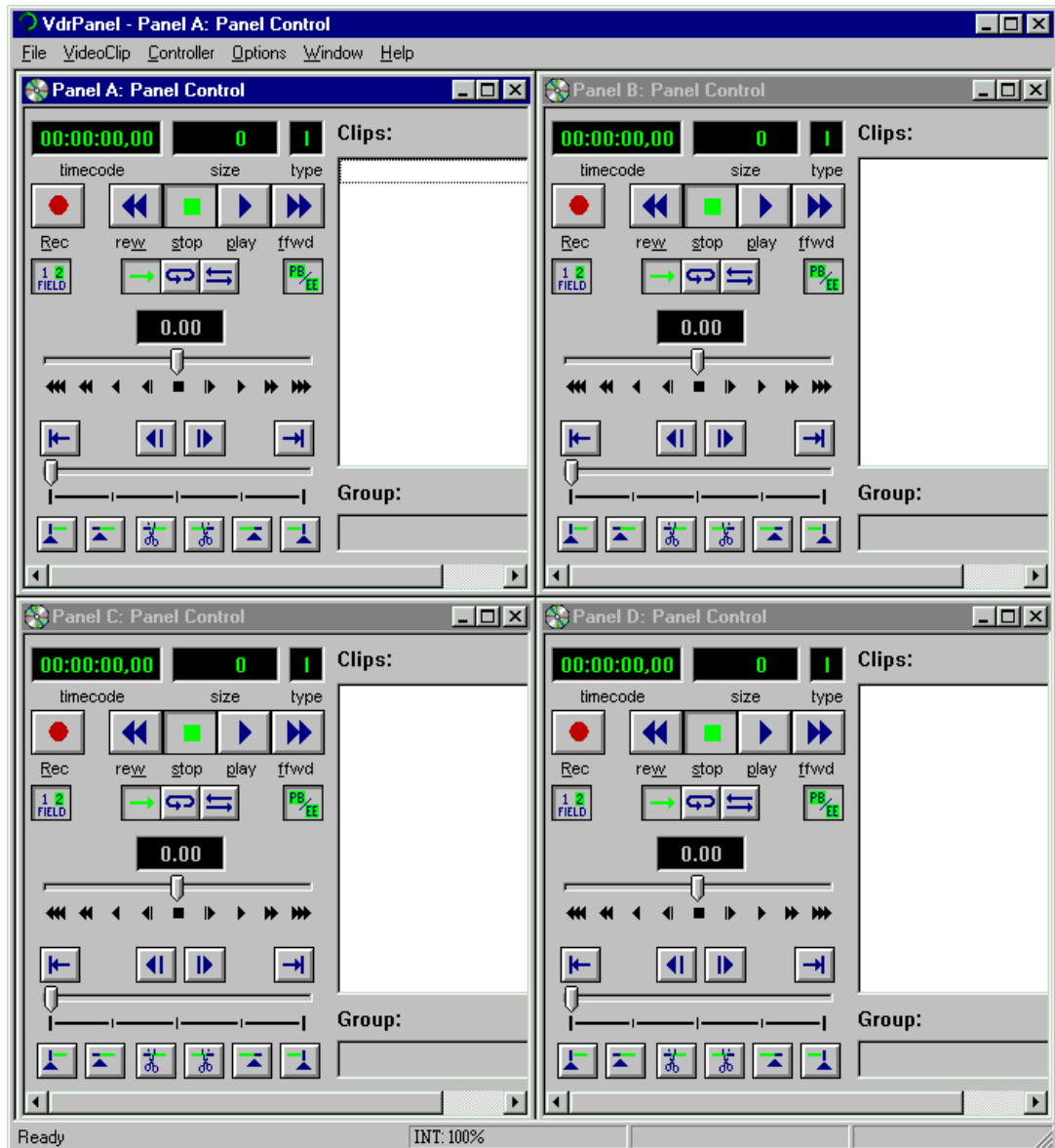

Figure 3-3. Profile VdrPanel



## Configuring Your Profile System

Before you can use your Profile system to record and playback clips, you must perform the tasks listed below.

- If your system includes one or more disk based external storage devices, you must use the Profile Disk Utility to make a file system. (See “Using the Profile Disk Utility” in the *Profile Family User Manual*.)
- Configure Video I/O, Audio I/O, Reference Genlock, and Time Code. (See discussions in the *Profile Family User Manual* on the Configuration Manager and the applications software you will be using.)

**NOTE:** *If you have Analog Audio I/O, use Configuration Manager to ensure that analog audio inputs are enabled and that analog audio outputs are unmuted.*

For information on configuring your Profile system for Ethernet and Fibre Channel networks, see Chapter 4, “Networking Your Profile System”.

## Updating an Emergency Repair Disk

Whenever you upgrade your software or change your system configuration, Grass Valley Group strongly recommends that you update the emergency repair disk shipped with your Profile system. This will allow you to restore system configuration in the event the operating system has a major problem.

To update your emergency repair disk, you need the 3.5inch floppy disk labeled *Emergency Repair Disk* that was shipped with your Profile system, or any blank 3.5 inch floppy disk properly labeled.

**NOTE:** *The emergency repair disk is Profile system specific. Make sure that the emergency repair disk is clearly marked with the unit’s serial number.*

To update the Emergency Repair Disk:

1. From the Start menu, choose the **RUN** command.
2. Enter **rdisk /s** in the Run dialog box, then press the Enter key or click **OK**. The Saving Configuration progress bar appears.
3. When the Setup dialog box appears, click **Yes** to create an emergency repair disk.
4. Insert your existing emergency repair disk or a blank 3.5 inch floppy disk in the Profile system floppy drive and click **OK**. The Formatting Disk progress bar appears.
5. When the operation is complete, remove the emergency repair disk from the Profile system and store it in a safe location.



## Installation Verification

To verify that your Profile system has been correctly installed, perform the following:

1. From the VdrPanel application, record a clip which contains both audio and video (not Black).
2. Play back the clip.

If you get any errors, check the following:

- If you have Black with the audio, recheck the Video I/O crosspoint set up in VdrPanel. (Refer to the *Profile Family User Manual*.) Make any necessary changes and repeat Steps 1 and 2 above.
- If you have the video, but have an audio problem, recheck your Audio I/O configuration through Configuration Manager. Also, recheck the audio assignments in VdrPanel application. (Refer to the *Profile Family User Manual*.) Make any necessary changes and repeat Steps 1 and 2 above.
- For other errors, see “Initial Power On Checks”.
- If errors persist, check the Profile Error Log and contact your Grass Valley Group representative. (See the *Profile Family User Manual*, “Using Profile Utilities” to access the Profile Error Log.)

## Initial Power On Checks

Grass Valley Group has made every effort to insure that your Profile system was in perfect operating condition before it left the factory. However, unforeseeable problems can occur. The discussion below applies to initial installation only. See the Profile Video File Server Service Manual for any post-installation problems.

***NOTE: Please take notes of trouble indications and what you do in attempting to correct any problem. Doing so will assist Customer Support and Field Service personnel in the event additional action is required.***

If you have a problem with the initial Profile system power On:

- First check all connections and power switches.
- Check the status of the Profile front panel LED indicators.

If the large green LED just to the left of center is not lit, replace the power cord and try again. If this problem still exists, contact your Grass Valley Group representative.

If one or more of the eight green Disk Activity LEDs remains lit or stays lit for a long time, power the Profile system Off and then back On again. If this problem still exists, power the Profile system Off and contact your Grass Valley Group representative.

If the **OVERTEMP** and/or the **FAN FAULT** red LED is On, immediately power the Profile system Off and contact your Grass Valley Group representative.

- Check to see if your system includes one or more disk based external storage devices. If so, you must use the Profile Disk Utility to create a file system on these disks at initial installation. (See the Profile Disk Utility discussion in the *Profile Family User Manual*.)



- Check the status of the rear panel LEDs three to four minutes after power On. Compare with the status listed in Table 3-1. Not all of the boards listed may be installed in your Profile system. Refer to Tables 1-2 through 1-5 in Chapter 1 pages 1-9 through 1-12, for the standard location of these boards.

**Table 3-1. Rear Panel Board Indicators**

<b>Board</b>	<b>Status/Description</b>
AUDIO I/O Digital AES/EBU	Red LED should be off. (On at power up and then off after a few minutes.)
VIDEO IN Analog Component	Red LED should be off. (On at power up and then Off after a few minutes.)
VIDEO OUT Analog Composite	Red LED should be off. (On at power up and then off after a few minutes.)
FIBRE CHANNEL	Red LED should be on.
DISK RECORDER Master/Slave	Red LED(s) should be off. (On at power up and then off after a few minutes.)
MPEG Encoder/Decoder	Red LED(s) should be off. (On at power up and then off after a few minutes.)
MPEG Decoder	Red LED(s) should be off. (On at power up and then off after a few minutes.)
DVCPRO Codec	Red LED should be off. (On at power up and then off after a few minutes.)
VIDEO I/O Serial Digital Component	Red LED should be off. (On at power up and then off after a few minutes.)
VIDEO I/O Analog Composite	Red LED should be off. (On at power up and then off after a few minutes.)
REFERENCE Analog Video	Red LED should be off. (On at power up and then off after a few minutes.)

If all LEDs are as indicated in Table 3-1, run the diagnostics below. If board LEDs are not as indicated, contact your Grass Valley Group representative.

## System Board Diagnostics

Run system board diagnostics if you have a problem and the rear panel LEDs are not as indicated in Table 3-1. To run system board diagnostics:

1. Quit all Profile System Software by selecting **Quit** or **Exit** from the File menu.
2. Wait approximately 30 seconds after all applications are shutdown.
3. From the Start menu choose Programs, PDR Debug Tools, **PDR Diagnostics**. The **Main Diagnostics** window appears, but the test buttons are not active.
4. Click **Yes** in the Close Applications messages box. After a short time, the **Main Diagnostics** test buttons become active.

You may get a message

### Checking availability of VDR Services. Please wait

Wait approximately a minute for this message to clear from the screen before proceeding.

The **Main Diagnostics** window is comprised of three panels. The panel on the left contains buttons which identify the boards installed in each of the slots, J1 - J17. Selecting a button brings up the test control buttons for that board's diagnostics in the upper right panel of the window and loads the i960 diagnostics program for that board. Selecting one of the tests executes that test and test results are then shown in the lower right panel of the diagnostics window.

5. Select the **Master EDR** button in the board slot ID region on the **Main Diagnostics** window. Test control buttons for the Master EDR board appear.

Another window, called **DRSTART** momentarily appears and is then replaced by a **GDB960** window and i960 diagnostics is loaded into EDR memory. Test results will appear in this window which remains open until you exit the Master EDR board menu.

6. When a **READY** prompt appears in the GDB960 window, select the **All Tests** button on the Master EDR board menu.
7. Observe the messages which appear in the GDB960 window. If any **\*\*FAILED\*\*** message appears, the EDR Master board is bad and needs to be replaced.
8. If no failures are noted, at the end of the tests, when **READY** re-appears, select **Done** in the Master EDR board menu.
9. If you have a Slave EDR, repeat Steps 3 through 6 for the **Slave EDR** button.
10. From the Diagnostics menu bar, select **Tests/All Board Tests**.

This executes diagnostics for all installed boards. The All Board Tests diagnostic is dependent on the Enhanced Disk Recorder boards previously tested. Fully loaded systems take from 10 to 15 minutes to complete the tests. Once initiated, you cannot cancel this diagnostics operation.



11. Select **Quit** to exit the Main Diagnostics window.

If you have any board failures or any other unresolved installation problems, contact your Grass Valley Group representative. See “Grass Valley Group Product Support” at the front of this manual.

12. Once you have checked all the boards, shutdown and restart Windows NT and then perform “Installation Verification” on page 3-7.

To shutdown and restart the Profile System:

- a. Press the CTRL+ALT+DEL key sequence.
- b. Select **Shutdown and Restart**.
- c. Select **OK**.

This concludes the System Board Diagnostic procedure.

---

# **Networking Your Profile System**

This chapter contains information about the Profile system and Ethernet configurations, and how to connect your Profile Video File Server for Ethernet and Fibre Channel networking.

## **Network Configurations**

The Profile Video File Server has both an Ethernet network interface (standard) and a Fibre Channel network interface (optional). If you are connecting your Profile system to only an Ethernet network, see “Connecting Ethernet” on page 4-4.

Profile Video Networking requires both a Fibre Channel network and an Ethernet network. Fibre Channel provides connectivity for high speed media data transfers between two or more Profile systems. The Ethernet network provides for exchange of command and status information between systems.

Building a network of more than two Profile systems requires an Ethernet hub (or connections to an existing Ethernet network) **and** a Fibre Channel hub. In this network configuration, Grass Valley Group recommends that you begin by configuring and testing the network with only two Profile Systems connected to the Ethernet and Fibre Channel hubs. This will ensure that all components are working and are correctly configured before adding additional Profile systems to the Ethernet and Fibre Channel networks.

## **Network Models**

The following discusses three examples of Ethernet and Fibre Channel networking. The first example shows connection of several Profile systems using an Ethernet hub (or existing Ethernet network) and a Fibre Channel hub. The second example of Ethernet and Fibre Channel networking shows an example of cascading several hubs. The third example shows a point to point connection for two Profile systems.



## Networking Several Profile Systems

If you want to connect more than two Profile systems together for video networking, you will need to connect each system to an Ethernet hub or an existing Ethernet network and a Fibre Channel hub. Figure 4-1 shows an example of this configuration.

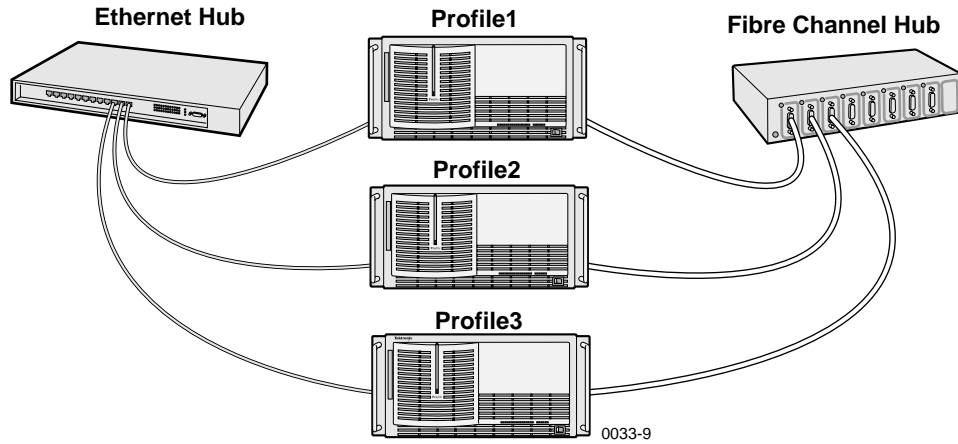

Figure 4-1. Basic Hub Connections

## Cascading Several Hubs

Connecting hubs together provides a way to add more and more systems to the network. Large Fibre Channel networks will probably not perform as well as smaller ones due to bandwidth limitations. Figure 4-2 shows a network using cascaded hubs.

The number of hubs required depends on the number of connections supported by each hub. Remember that one of the connections is needed to connect to the next hub. You must use appropriate cables for the distance between devices.

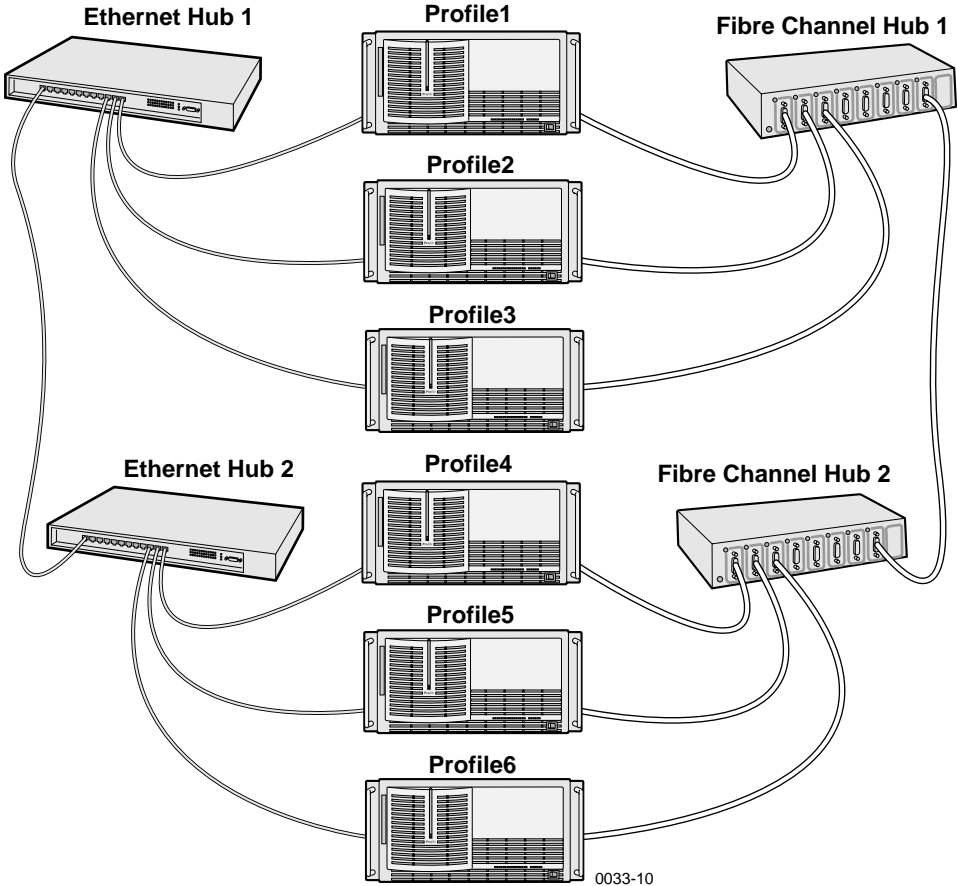

Figure 4-2. Cascading Several Hubs

### Point to Point Network Connection

The simplest network connection is the point-to-point connection shown in Figure 4-3. This method allows you to connect two Profile systems together. The Fibre Channel connection can be made using a Fibre Channel cable. The Ethernet connection can be made using an Ethernet hub or an Ethernet crossover cable.

**NOTE:** *The Ethernet crossover cable required for point to point Ethernet connection is not shipped with the Profile system. Also, for point to point connection, both Profiles must be powered on at the same time.*

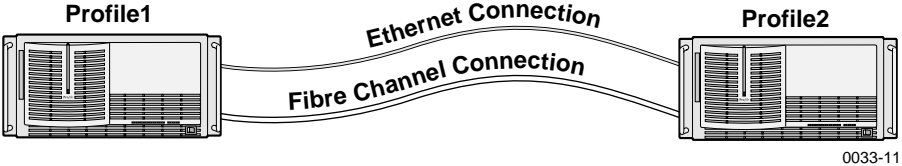

Figure 4-3. Point-to-Point Network Connection



## Connecting Ethernet

The Profile system supports a 10/100BASE-T Ethernet interface. Figure 4-4 shows the location of the 10/100BASE-T Ethernet interface connector on the System CPU board in slot J1. See Appendix B for connector pin-out information.

To connect your Profile system to Ethernet:

1. Turn the Profile system power Off. (See page 3-2 for power on/off procedures.)
2. Connect the Ethernet cable to the Profile system Ethernet connector as shown in Figure 4-4.
3. Power On your Profile system and configure the Ethernet board IP address as described in “Configuring Ethernet for TCP/IP”, page 4-5.
4. If you are also connecting Fibre Channel, proceed to “Connecting Fibre Channel”, page 4-6.

If a problem occurs, see “Initial Power On Checks”, page 3-7.

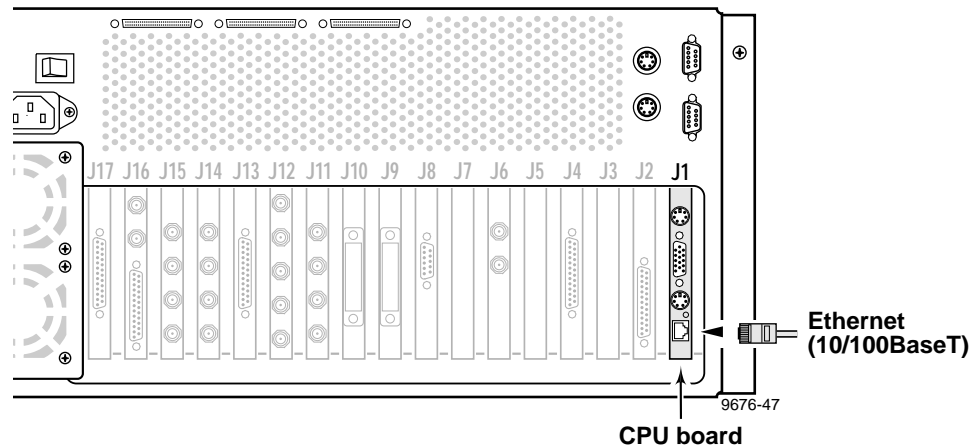

Figure 4-4. System Ethernet Connector

## Ethernet Interface Configuration

You must set the Ethernet Interface driver to match the speed of your network, either 10BaseT or 100BaseT. To set the Ethernet Interface speed:

1. Choose **Settings | Control Panel** from the **Start** menu.
2. Double-click **Network**, then select the **Adapters** tab in the Network dialog box.
3. Select the **Intel EtherExpress PRO Adapter**, then click the **Properties** button.
4. In the Properties dialog box, click the **Settings** button for the Intel EtherExpress PRO Adapter.
5. In the Basic Settings panel, select the appropriate speed, either 10Mbps or 100Mbps, from the Network Speed drop-down list box.

**NOTE:** *The Auto speed setting may not work correctly with some Ethernet hubs and switches. Grass Valley Group does not recommend the use of the Auto setting.*

6. Click **OK** to close all of the open dialog boxes, and reboot your system.



## Configuring Ethernet for TCP/IP

**NOTE:** *If you are connecting to an existing TCP/IP network, you must contact your network administrator before proceeding with TCP/IP configuration. Please review this procedure with your network administrator before performing it.*

The following steps assume that you **are not** connecting to an **existing** TCP/IP network.

To configure Ethernet board IP Address:

1. Logon as Administrator
  - a. Hold the Shift key down during start-up to prevent auto-logon as *profile*. Be sure to continue holding the shift key until the logon dialog box appears.
  - b. Log in as *administrator*. The factory default *administrator* password on a Profile system is *triton*.
2. Select **Start | Settings | Control Panel | Network**
3. In the Network window, select the **Protocols** tab and then double click on **TCP/IP Protocol**.
4. You must fill in two fields in the IP Address tab; IP Address and Subnet Mask. For the IP Address, we recommend the following numbering convention. Note that each Profile system **must** have a unique IP address.

For the first Profile system, use 128.181.1.1  
For the second Profile system, use 128.181.1.2  
For the third Profile system, use 128.181.1.3  
etc. ...
5. For the Subnet mask, use the same value on all Profile systems: 255.255.255.0 and then click **OK** to close the TCP/IP Protocol window.
6. Click **OK** to close the Network window and then restart Windows NT.

## Testing Your Ethernet Connection

To test your Ethernet connection:

1. Verify TCP/IP connectivity between Profiles by opening a command prompt window and typing **ping 128.181.1.n**, where n is the number for this Profile system, and then pressing **Enter**.
2. Check for a reply.
3. Repeat step 1 and 2 using the IP address for another Profile system in the network.



## Connecting Fibre Channel

Figure 4-5 shows the connection of several Profile systems to a Fibre Channel Hub using fibre channel cables. See Appendix B for fibre channel board connector pin-out information.

Recommended Maximum Fibre Channel cable lengths are:

- Up to 25 meters: Copper cable.
- Up to 500 meters: Multi-mode optical cable with optional Media Interface Adapters (copper-to-fiber optic adapter).

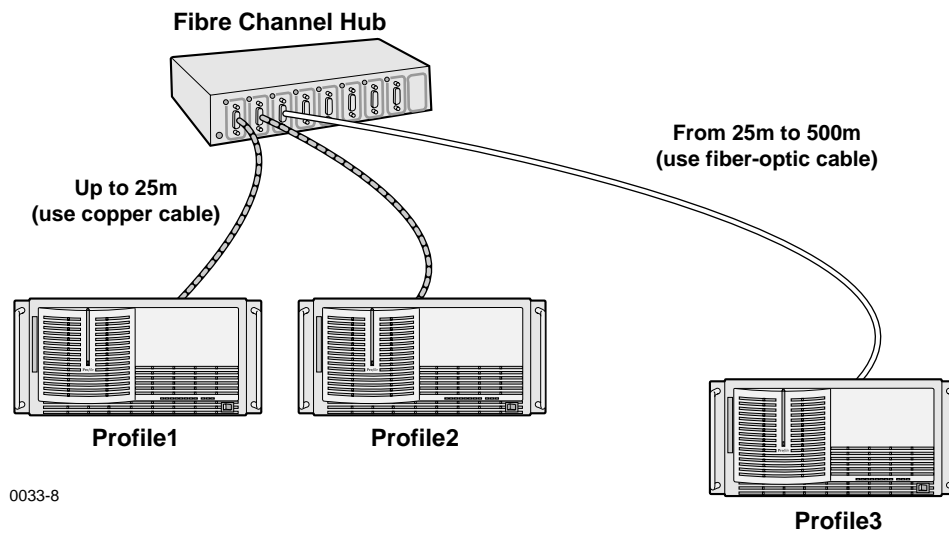
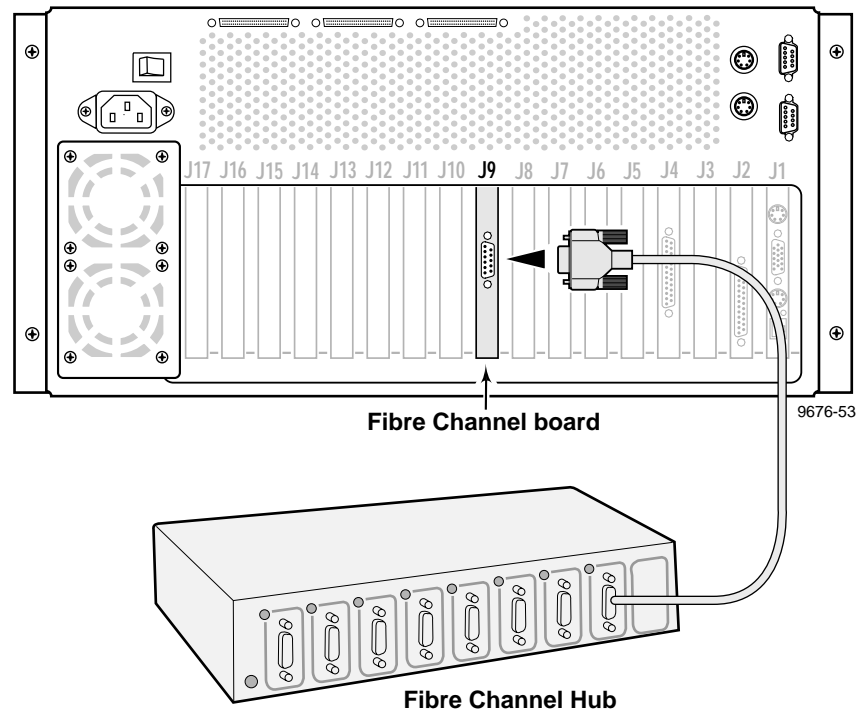

Figure 4-5. Example of Profile System and Fibre Channel Connections

**NOTE:** The Fibre Channel Hub may be supplied with caps over the connectors. To maintain EMI compliance, only remove caps as necessary. If you disconnect a Profile system from the hub, place a cap on the vacant connector.

To connect your Profile system to a Fibre Channel network:

1. Turn Profile system power Off. (See page 3-2 for power on/off procedures.)
2. Connect the Fibre Channel cable from the board to the Fibre Channel hub (Figure 4-6).



**Figure 4-6. Fibre Channel Board and Hub Connection**

3. Turn Profile system power On.
4. You must now configure the Fibre Channel board for use in your video network environment. Refer to the *Profile Family User Manual* for information on how to do this.

If a problem occurs, see “Initial Power On Checks”, page 3-7, and “System Board Diagnostics”, page 3-9.



# **Specifications**

## **General Information**

This appendix provides tables of electrical specifications for the video and audio characteristics, as well as environmental criteria and power and mechanical characteristics. The tables in this appendix make it easier to present the specifications in numerical values. The following terms apply to the Profile Video File Server Characteristics and Descriptions in the tables.

**Specification:** A document or a section of a document that lists and describes characteristics and performance requirements of equipment and certain program material.

**Requirement (Performance Requirement):** A statement that defines a characteristic, usually in limit form.

**Supplemental Data:** Statements that explain performance requirements or provide performance information. These are not considered to be statements of guaranteed performance and are not ordinarily supported by a performance check procedure.

## **Test Equipment**

Grass Valley Group uses the following test equipment to verify the performance requirements listed in this chapter.

- VM700A
- Signal Source (Video and Audio)
- Signal Generator
- Monitor



## Electrical Specifications

The Performance Requirements listed in the Electrical Specifications apply over an ambient temperature range of +20.5 C to +30.5 C. The Performance Requirement tolerances listed in the Electrical Specification are doubled over the temperature range of 0 to +40.5 C, unless there is a specific exception.

**Table A-1. Serial Digital Video Input/Output**

Characteristics	Description
Number of Inputs	<i>Supplemental Data:</i> Two component serial digital
Input Type	<i>Supplemental Data:</i> 75Ω terminated
Number of Outputs	<i>Supplemental Data:</i> Two component serial digital
Output Timing Range	<i>Requirement:</i> -21/2 H to +148 H <i>Supplemental Data:</i> Independent for each output <i>Supplemental Data:</i> Resolution; 74 ns
Digital Format	<i>Supplemental Data:</i> CCIR 601 Component 525/625 8 bit data, Scrambled NRZI; complies with SMPTE 259M and CCIR 656
Bit Rate	<i>Supplemental Data:</i> 270 Mb/s
Source Impedance	<i>Supplemental Data:</i> 75Ω
Return Loss	<i>Supplemental Data:</i> ≥15 dB from 5 MHz to 270 MHz
DC Offset	<i>Requirement:</i> 0 ±0.5V
Rise and Fall Times	<i>Requirement:</i> 400 - 1000ps; 20% to 80% amplitude slew rate
Jitter	<i>Requirement:</i> ≤±360 ps
Input Level	<i>Supplemental Data:</i> 800 mV p-p ±10% <i>Supplemental Data:</i> Input voltages outside this range may cause reduced receiver performance
Serial Receiver Equalization Range	<i>Requirement:</i> Proper operation with up to 17 dB loss at 135 MHz using coaxial cable having $1/\sqrt{F}$ loss characteristics. 800 mV launch amplitude
Output Level	<i>Requirement:</i> 800 mV p-p ±10% <i>Supplemental Data:</i> Can be adjusted for 740 mV p-to-p ±10%

**Table A-2. Analog Composite Video Output**

Characteristics	Description
Program Gain	<i>Requirement:</i> 1 ±1%
Frequency Response	<i>Requirement:</i> 500 kHz to 5.8 MHz ±2% <i>Supplemental Data:</i> -3 dB Nominally 6.25 MHz
Signal-to-Noise Ratio	<i>Requirement:</i> > 50 dB
Chrominance-to-Luminance Delay Error	<i>Requirement:</i> ≤10 ns NTSC ≤15 ns PAL
Differential Gain	<i>Requirement:</i> ≤1% NTSC ≤1.5% PAL
Differential Phase	<i>Requirement:</i> ≤1°
K-Factor	<i>Requirement:</i> ≤1%
2T Pulse-to-Bar Ratio	<i>Requirement:</i> ≤1%
Output Timing Range	<i>Requirement:</i> -21/2H to +148H <i>Supplemental Data:</i> Independent for each output <i>Supplemental Data:</i> Resolution; ≈0.3° of 3.58 MHz <i>Supplemental Data:</i> Timing Stability: 1°
Sync and Burst Insertion	<i>Requirement:</i> Meets RS-170A, and CCIR RPT 624-3; always on
Insertion Phase Error	<i>Requirement:</i> ≤1°
Chrominance Phase Error with Reference Burst Frequency Change	<i>Requirement:</i> ≤1° with an input burst frequency change of ±10 Hz
Chrominance Phase Error with Reference Signal Amplitude Change	<i>Requirement:</i> ≤1° with a ±3 dB amplitude change
DC Offset	<i>Requirement:</i> ≤±50 mV
Inserted Sync and Burst Amplitude Accuracy	<i>Requirement:</i> Sync NTSC 40 IRE ±1 IRE PAL 300 mV ±7 mV Burst NTSC 40 IRE ±1 IRE PAL 300 mV ±7 mV
Inserted Sync and Burst SCH Phase Accuracy	<i>Requirement:</i> 0° ±5°
Black Level Error	<i>Requirement:</i> ±3.5 mV

**Table A-3. Analog Composite Video I/O**

Characteristics	Description
<b>Inputs (without TBC)</b>	
Return Loss	≥40 dB to 5MHz
Genlock	Locks to (and remain locked) to incoming Black Burst -3 dB to +6 dB from nominal. PAL nominal - Sync @ 300mV; Burst @ 300mV NTSC nominal - Sync @ 40 IRE; Burst @ 40 IRE  White noise immunity - Remains locked with signal-to-noise ratio >20dB.  Hum rejection - Remains locked with 60Hz hum <1V p-p.
Decoding modes	Notch and Adaptive Comb modes operational.
<b>Outputs</b>	
Inserted Sync and Burst	PAL 300 mV ±21 mV NTSC 40 IRE ±3 IRE
Inserted Sync and Burst SCH Phase	0° ±5°
Signal-to-Noise Ratio	>58dB
K-factor	≤2%
Supported video formats	PAL and NTSC
Return Loss	≥40 dB to 5MHz
<b>Analog Video Quality E-E (Direct Input-Output)</b>	
Gain	1 ±1%
Program Input Gain Range	±3dB
Black Level Error	±5mV from inserted Sync and Burst blanking level.
Frequency Response	PAL - ≤0.2dB from 500kHz to 4.8MHz. NTSC - ≤0.2dB from 500kHz to 4.2MHz.
Chrominance to Luminance Delay	≤20nS
Differential Gain	≤2%
Differential Phase	±2°
Signal-to-Noise Ratio	>50dB
K-factor	≤2%
2T Pulse-to-Bar Ratio	≤2%
Insertion Timing Error	≤5nS

Note: Analog Composite I/O specifications are applicable when TBC is not enabled. The image quality of any channel with TBC enabled is comparable to professional Super VHS recorder/playback quality. For optimal image quality, and if not required, TBC should be disabled.



**Table A-4. Component Analog Video Input**

Characteristic	Specification
Input connectors:	BNCx (3) terminating
Impedance:	75 ohms
Return loss:	≤ -40dB to 5.0MHz
Input formats supported (525/60):	Betacam Betacam without setup Betacam (non-EBU) MII MII without setup (SMPTE/EBU-N10) GBR (700mv no setup)
Input formats supported (625/50):	SMPTE/EBU-N 10 Betacam (non-EBU) GBR (700mv no setup)
Reference:	Sync on Y/G video input

**Table A-5. Component Analog Video Performance**

Characteristic	Specification
A to D conversion:	<i>Supplemental Data:</i> 10 bits at 27 MSPS on all 3 inputs
Output video data:	<i>Supplemental Data:</i> Dynamically rounded (dithered) to 8 bits
Input gain controls:	<i>Requirement:</i> Each CAV input is software adjustable ±3dB except MII, which is software adjustable +2.5/-3dB.
Input Setup Controls	<i>Requirement:</i> ±20 mV <i>Supplemental Data:</i> Software adjustable
Frequency response:	<i>Requirement:</i> (Y) ±0.25 dB 0-5.8MHz (Cb/Cr) ±0.25 dB 0-2.75 MHz
Signal-to-Noise Ratio	<i>Requirement:</i> > +50dB
Relative timing error:	<i>Engineering Note:</i> Y to Cb/Cr, <5ns by design Cb to Cr, <5ns by design Measurement accuracy ±5ns
Internal Sync (Y/G input) timing:	<i>Requirement:</i> Digital video output H position error <25ns w.r.t. input sync <i>Engineering Note:</i> CAV auto-timing ON. Input signal timed to Genlock Black Burst.
Standards selection:	Software selectable 525/625
Gain Accuracy	<i>Requirement:</i> All supported input formats translated to ±1% of SMPTE/EBU-N10 levels given in Tables 2-9 and 2-10. <i>Supplemental Data:</i> 75% bars with 100% flag
K Factor K-2T (Y) K-4T (B-Y) K-4T (R-Y)	<i>Requirement:</i> ≤1% <i>Supplemental Data:</i> Component K factor measurement @ VM700
K Pulse-to-Bar	<i>Requirement:</i> ±1% K factor <i>Supplemental Data:</i> Component K factor measurement @ VM700



**Table A-6. Format Voltage Level Definitions for CAVmtrxN Colorbar Matrix Test Clip**

<b>Format</b>	<b>White</b>	<b>Yellow</b>	<b>Cyan</b>	<b>Green</b>	<b>Magenta</b>	<b>Red</b>	<b>Blue</b>	<b>Black</b>
<b>SMPTE/EBU-N10 (MII w/o setup)</b>								
Y	700	465.2	368	308.2	216.8	157.0	59.9	0
B-Y	0	-262.5	88.6	-173.9	173.9	-88.6	262.5	0
R-Y	0	42.7	-262.5	-219.8	219.8	262.5	-42.7	0
<b>MII</b>								
Y	700	482.8	392.9	337.6	253.1	197.7	107.9	52.5
B-Y	0	-242.8	81.9	-160.9	160.9	-81.9	242.8	0
R-Y	0	39.5	-242.8	-203.3	203.3	242.8	-39.5	0
<b>Betacam</b>								
Y	714.3	492.6	400.9	344.4	258.2	201.7	110.1	53.6
B-Y	0	-350	118.1	-231.9	231.9	-118.1	350	0
R-Y	0	56.9	-350	-293.1	293.1	350	-56.9	0
<b>Betacam w/o setup</b>								
Y	714.3	474.6	375.5	314.5	221.2	160.2	61.1	0
B-Y	0	-378.4	127.7	-250.7	250.7	-127.7	378.4	0
R-Y	0	61.5	-378.4	-316.8	316.8	378.4	-61.5	0
<b>Betacam w/o setup (non-EBU)</b>								
Y	700	465.2	368	308.2	216.8	157.0	59.9	0
B-Y	0	-350	118.1	-231.9	231.9	-118.1	350	0
R-Y	0	56.9	-350	-293.1	293.1	350	-56.9	0
<b>GBR</b>								
G	700	525	525	525	0	0	0	0
B	700	0	525	0	525	0	525	0
R	700	525	0	0	525	525	0	0

**Table A-7. Format Voltage Level Definitions for CAVmtrxP Colorbar Matrix Test Clip**

Format	White	Yellow	Cyan	Green	Magenta	Red	Blue	Black
<b>SMPTE/EBU-N10</b> (MII w/o setup)								
Y	700	465.2	368	308.2	216.8	157.0	59.9	0
B-Y	0	-262.5	88.6	-173.9	173.9	-88.6	262.5	0
R-Y	0	42.7	-262.5	-219.8	219.8	262.5	-42.7	0
<b>Betacam w/o setup</b> (non-EBU)								
Y	700	465.2	368	308.2	216.8	157.0	59.9	0
B-Y	0	-350	118.1	-231.9	231.9	-118.1	350	0
R-Y	0	56.9	-350	-293.1	293.1	350	-56.9	0
<b>GBR</b>								
G	700	525	525	525	0	0	0	0
B	700	0	525	0	525	0	525	0
R	700	525	0	0	525	525	0	0

**Table A-8. Program Input Genlock**

Characteristics	Description
Burst Frequency Lock Range	<i>Requirement:</i> $\pm 50$ Hz at subcarrier <i>Supplemental Data:</i> Remains locked or initial lock
Signal Amplitude Lock Range	<i>Requirement:</i> Stays locked to +6 dB and -3 dB
Phase Jitter (Analog Input and Analog Output)	<i>Requirement:</i> $\leq 1^\circ$
Phase Jitter (Analog Output Only)	<i>Requirement:</i> $\leq 0.5^\circ$
Hum Rejection	<i>Requirement:</i> $\geq 32$ dB
Recovery Time	<i>Requirement:</i> Fast - Within 35.7 mV in 2 to 3 lines Medium - Within 35.7 mV in 10 to 30 lines Slow - Within 35.7 mV in > 30 lines
Switch Points	<i>Requirement:</i> Fast - Medium 30 to 40 dB signal-to-noise <i>Supplemental Data:</i> Medium - Slow 20 to 30 dB signal-to-noise

**Table A-9. Reference Genlock**

Characteristics	Description
Color Field Detection, Based on SCH Phase	<i>Requirement:</i> Correct color framing for signals having an average SCH phase $\pm 40^\circ$ ; Lockup $\pm 10^\circ$ <i>Supplemental Data:</i> Once locked to color field, it will stay locked over a range of $0^\circ$ to $\pm 90^\circ$
Burst Frequency Lock Range	<i>Requirement:</i> PAL, $\pm 10$ Hz at subcarrier NTSC, $\pm 20$ Hz at subcarrier
Signal Amplitude Lock Range	<i>Requirement:</i> Stays locked to +6 dB and -3 dB
Reference Genlock Input Return Loss	<i>Requirement:</i> $\geq 40$ dB to 5 MHz

**Table A-10. Time Code**

Characteristics	Description
Input	<i>Supplemental Data:</i> Longitudinal Time Code. AC coupled, differential input
Input Impedance	<i>Supplemental Data:</i> 20 k $\Omega$ . Switch selectable 600 $\Omega$ input.
Input Amplitude	<i>Supplemental Data:</i> 0.1 V p-p, differential, minimum
Maximum Input Voltage	<i>Supplemental Data:</i> 2.5 V p-p, differential, maximum

**Table A-11. Analog Audio**

Characteristics	Description
Through Gain	<i>Requirement:</i> 1 ±1 dB <i>Supplemental Data:</i> Non-mix mode each of four channels
Frequency Response	<i>Requirement:</i> 20 Hz to 20 kHz, with between +0.5 dB, -2 dB maximum deviation from flatness at 48 kHz sample rate
Input Impedance	<i>Supplemental Data:</i> 600 Ω or 20 kΩ each channel
Input/Output Signal Levels	<i>Supplemental Data:</i> Nominal Line Level: 0 dBu Nominal Peak Line Level: +9 dBu Digital Clipping: +18 dBu (16-bit quantization)
THD+N at 1020 Hz and 60 Hz	<i>Requirement:</i> -70 dBm (0.031%) at +9dBu input

**Table A-12. Digital Audio**

Characteristics	Description
Bit Rate	<i>Supplemental Data:</i> 270 Mb/S
Return Loss	<i>Supplemental Data:</i> 15 dB from 5 MHz to 270 MHz
Input Impedance	<i>Supplemental Data:</i> 75 Ω
Output Amplitude	<i>Requirement:</i> 800 mV p-p, ±80 mV.
Output DC Level	<i>Requirement:</i> 0 V, ±0.5 V
Output Rise and Fall Time	<i>Requirement:</i> 400 pS to 1000 pS between 20% and 80%
Jitter	<i>Requirement:</i> ≤ either 0.2ui or 720 pS p-p

**Table A-13. Profile Video File Server Power Source**

Characteristics	Description
Electrical Rating	<i>Requirement:</i> 100 -240V, 50/60 Hz, 10A maximum
Supply Type	<i>Supplemental Data:</i> Single Phase
Supply Connection	<i>Supplemental Data:</i> Detachable cord set
Power Consumption	<i>Supplemental Data:</i> <600 VA



**Table A-14. Profile Video File Server Power Supply Specifications (from Manufacturer)**

Characteristics	Description
Output voltages	<i>Supplemental Data:</i> +5Vdc @ 70 A max. -5Vdc @ 5 A max. +12Vdc <sub>1</sub> @ 10 A max. +12Vdc <sub>2</sub> @ 6 A max. -12Vdc @ 6A max.
Total wattage	<i>Supplemental Data:</i> 1000 W maximum
Ripple	<i>Supplemental Data:</i> 200 mV p-p on + 5V supply 50 mV p-p on -5V supply 120 mV p-p on +12V supplies 225 mV p-p on -12V supply
Regulation	<i>Supplemental Data:</i> ±3% on +5, -5, and -12 V supplies ±5% on +12 V supplies

## Environmental Criteria

Table A-15 lists the environmental criteria for the Profile Video File Server and the PAC208/216.

**Table A-15. Environmental Criteria**

Characteristics	Description
Operating Temperature	<i>Requirement:</i> 5° to 40°C (+41° to 122°F)
Storage Temperature	<i>Requirement:</i> -40° to 65°C (-40° to 149°F)
Operating Altitude	<i>Requirement:</i> To 15,000 feet (4572 meters) <i>Supplemental Data:</i> IEC 950 compliant to 2000 meters
Storage Altitude	<i>Requirement:</i> To 50,000 feet (15,240 meters)
Mechanical Shock	Mil Specification: Mil-T-28800D, Class 6 (Non-Operating Only)
Transportation	<i>Requirement:</i> Qualified under NSTA Test Procedure 1A, Category II (24 inch drop)
Equipment Type	<i>Supplemental Data:</i> Information Technology
Equipment Class	<i>Supplemental Data:</i> Class I
Installation Category	<i>Requirement:</i> Category II Local level, appliances, portable equipment, etc.
Pollution Degree	<i>Requirement:</i> Level 2 Normally only non-conductive pollution occurs. Occasionally a temporary conductivity caused by condensation must be expected.
Humidity	<i>Requirement:</i> Operating 20% - 80% Non-Operating 8% - 90% Transportation 5% - 95% Maximum Wet Bulb Temperature 26° <i>Supplemental Data:</i> Do not operate with visible moisture on the circuit boards

## Mechanical Specifications

Table A-16 lists the dimensions for the Profile Video File Server chassis, the PAC 208/216 chassis, the XLR panels, and the BNC panel.

**Table A-16. Profile Video File Server Mechanical Specifications**

Item	Dimensions
PDR200/PDR300	Height: 8.720 inches (22.149 centimeters) Width: 19.000 inches (48.260 centimeters) Depth: 24.150 inches (61.341 centimeters)
PAC208/216	Height: 3.500 inches (8.89 centimeters) Width: 19.000 inches (48.260 centimeters) Depth: 19.000 inches (48.260 centimeters)
XLR Panel	Height: 3.500 inches (8.89 centimeters) Width: 19.000 inches (48.260 centimeters) Depth: 3.250 inches (8.255 centimeters)
BNC Panel	Height: 1.750 inches (4.445 centimeters) Width: 19.000 inches (48.260 centimeters) Depth: 3.250 inches (8.255 centimeters)

## PAC 208/216 Power Requirements

Table A-17 lists the power requirements for the PAC 208/216.

**Table A-17. PAC208/216 Power Requirements**

Characteristic	Specification
Voltages/current from power supply	+5V, 1.9 A maximum
Typical Total Power	9.0 Watts typical
Maximum Heat Dissipation	32.42 BTU/hour (9.5 watts)





# Appendix **B**

## Connector Pin-outs

This appendix contains the pin-outs for the connectors at the rear panel of the Profile Video File Server.

### S-VGA Connector

The S-VGA monitor connector on the System CPU board in slot J1 is a high density 15-pin female connector. Figure B-1 shows the S-VGA Monitor connector and Table B-1 lists the pin-outs.

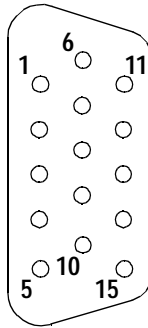

Figure B-1. S-VGA Monitor Connector

Table B-1. S-VGA Monitor Connector Pin-outs

Pin #	Signal	Pin #	Signal	Pin #	Signal
1	Analog Red Output	6	Ground	11	not used
2	Analog Green Output	7	Ground	12	not used
3	Analog Blue Output	8	Ground	13	Horizontal Sync
4	not used	9	not used	14	Vertical Sync
5	Ground	10	Ground	15	not used



## Ethernet Connector

The Ethernet connector located on the System CPU board in slot J1 is an 8-pin RJ-45 snap-in telephone-type connector which supports Category 5 unshielded twisted pair cable. Figure B-2 shows the RJ-45 connector and Table B-2 lists the pin-outs.

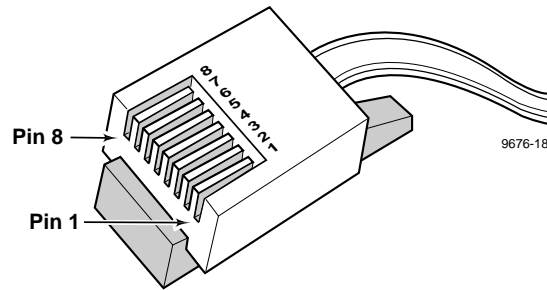

Figure B-2. Ethernet RJ-45 Connector

Table B-2. RJ-45 Connector Pin-outs

Pin #	Signal	Pin #	Signal
1	Transmit +	5	not used
2	Transmit -	6	Receive -
3	Receive +	7	not used
4	not used	8	not used

# Parallel Port Connector

Figure B-3. shows the parallel port connector in slot J2 and Table B-3 lists the pin-outs.

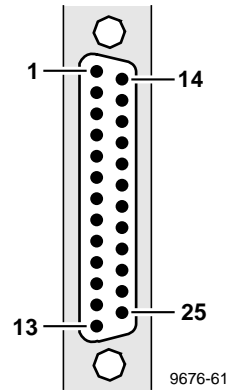

Figure B-3. Parallel Port Connector

Table B-3. Parallel Port Connector Pin-outs

Pin	Signal	Pin	Signal
1	STROBE/	14	AUTO FEED
2	PD(0)	15	ERROR
3	PD(1)	16	INIT
4	PD(2)	17	LCTIN/
5	PD(3)	18	GND
6	PD(4)	19	GND
7	PD(5)	20	GND
8	PD(6)	21	GND
9	PD(7)	22	GND
10	ACK	23	GND
11	BUSY	24	GND
12	PAPER ERROR	25	GND
13	SLCT		



## RS-232 Connectors

The Profile Video File Server has two RS-232 interface connectors on the rear panel. Figure B-4 shows a 9-pin RS-232 rear panel connector (both are male) and Table B-4 lists the pin-outs.

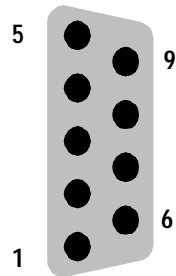

Figure B-4. RS-232 Connector Pin-outs

Table B-4. RS-232 Connector Pin-outs

Pin #	Signal	Description
1	DCD	Received line Signal Detector
2	RXD	Received Data
3	TXD	Transmitted Data
4	DTR	Data Terminal Ready
5	GND	Ground
6	DSR	Data Set Ready
7	RTS	Request To Send
8	CTS	Clear To Send
9	CE	Ring Detect

## SCSI Connector

The Profile Video File Server provides a number of 68-pin SCSI interface connectors at the rear panel, including the one on the SCSI board which is reserved for the PLS200 Library System.

For a 2-channel Profile, SCSI interfaces are identified as:

- SCSI A - Master EDR board rear panel connector
- SCSI B - Rear Panel connector

For a 4-channel Profile, SCSI interfaces are identified as:

- SCSI A - Master EDR board rear panel connector
- SCSI B - Rear Panel connector
- SCSI C - Slave EDR board rear panel connector
- SCSI D - Rear Panel connector

All SCSI connectors have the same pin-outs. This includes an internal SCSI interface that is used with the disk drives that are resident within the Profile Video File Server. Figure B-5 shows a SCSI connector and Table B-5 lists the pin-outs.

Note that in Table B-5, signals preceded by a dash (-) indicate signals that are true, asserted, and active when low.

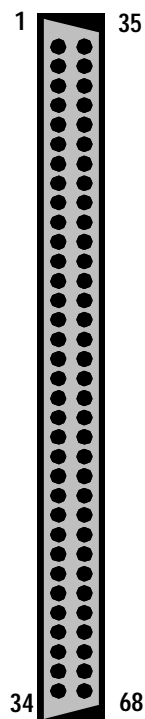

Figure B-5. 68 Pin SCSI Connector



**Table B-5. 68 pin SCSI Connector Pin-outs**

Pin #	Mnemonic	Signal Description	Pin #	Mnemonic	Signal Description
1	DB12	Data Bus bit 12	35	-DB12	Data Bus bit 12
2	DB13	Data Bus bit 13	36	-DB13	Data Bus bit 13
3	DB14	Data Bus bit 14	37	-DB14	Data Bus bit 14
4	DB15	Data Bus bit 15	38	-DB15	Data Bus bit 15
5	DB P1	Data Bus Parity (8-15)	39	-DB P1	Data Bus Parity (8-15)
6	GND	Signal Ground	40	GND	Signal Ground
7	DB0	Data Bus bit 0	41	-DB0	Data Bus bit 0
8	DB1	Data Bus bit 1	42	-DB1	Data Bus bit 1
9	DB2	Data Bus bit 2	43	-DB2	Data Bus bit 2
10	DB3	Data Bus bit 3	44	-DB3	Data Bus bit 3
11	DB4	Data Bus bit 4	45	-DB4	Data Bus bit 4
12	DB5	Data Bus bit 5	46	-DB5	Data Bus bit 5
13	DB6	Data Bus bit 6	47	-DB6	Data Bus bit 6
14	DB7	Data Bus bit 7	48	-DB7	Data Bus bit 7
15	DB P	Data Bus Parity (0-7)	49	-DB P	Data Bus Parity (0-7)
16	DIFFSENS	Differential (Drive) Sensor	50	GND	Signal Ground
17	TERMPWR	Termination Power	51	TERMPWR	Termination Power
18	TERMPWR	Termination Power	52	TERMPWR	Termination Power
19	Reserved	n.a.	53	Reserved	n.a.
20	ATN	Attention	54	-ATN	Attention
21	GND	Signal Ground	55	GND	Signal Ground
22	BSY	SCSI Bus Busy	56	-BSY	SCSI Bus Busy
23	ACK	Data Xfer Acknowledge	57	-ACK	Data Xfer Acknowledge
24	RST	Reset	58	-RST	Reset
25	MSG	Message	59	-MSG	Message
26	SEL	Select	60	-SEL	Select
27	C/D	(Control)Data	61	-C/D	Control(Data)
28	REQ	Data Xfer Request	62	-REQ	Data Xfer Request
29	I/O	Input/Output	63	-I/O	Input/Output
30	GND	Signal Ground	64	GND	Signal Ground
31	DB8	Data Bus bit 8	65	-DB8	Data Bus bit 8
32	DB9	Data Bus bit 9	66	-DB9	Data Bus bit 9
33	DB10	Data Bus bit 10	67	-DB10	Data Bus bit 10
34	DB11	Data Bus bit 11	68	-DB11	Data Bus bit 11

# Fibre Channel Connector

The Fibre Channel board uses a 9-pin subminiature D-type connector. Figure B-6 shows the connector and Table B-6 lists the pin-outs.

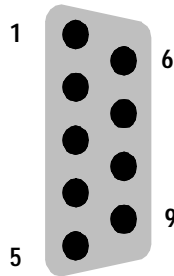

Figure B-6. Fibre Channel Connector

Table B-6. Fibre Channel Connector Pin-outs

Pin #	Mnemonic	Description
1	T <sub>x+</sub>	Differential Transmit Data IN
2	V <sub>cc</sub>	5VDC (nominal)
3	Fault	Module Fault Detect
4	KEY	Mechanical Key Position
5	R <sub>x+</sub>	Differential Receive Data OUT
6	T <sub>x-</sub>	Differential Transmit Data OUT
7	ODIS+	Optical Output Disable
8	GND	Signal Ground
9	R <sub>x-</sub>	Differential Receive Data In

## Fibre Channel Cable Specifications

Both copper wire and fiber cable specifications are given.

Copper wire:

Cable type: 150 ohm twinax copper wire  
 Maximum length: 30 meters (98 feet) (GLM dependent)  
 Connector type: DB9

Fiber:

Cable type: duplex zip cord, plenum grade  
 Connector type: SC Duplex

Fiber	Typical Length (meters)
50/125	300
62.5/125	500



## Reference Genlock D-Connector

The 25-pin male D connector on the Reference Genlock board provides eight Longitudinal Time Code (LTC) interfaces (four input channels and four output channels). The LTC Breakout cable with a DB25 connector on one end and eight XLR connectors on the other can then be connected to the Reference Genlock 25-pin D connector at the rear panel of the Profile. Figure B-7 shows the connector and Table B-7 lists the pin-outs.

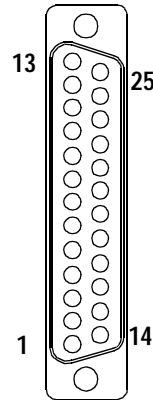

Figure B-7. Reference Genlock 25-pin Connector

Table B-7. Reference Genlock D-connector Pin-outs

Pin #	Description	Pin #	Description
1	Ch 0 Input +	14	Ch 0 Output Common
2	Ch 0 Input -	15	Ch 0 Output +
3	Ch 0 Input Common	16	Ch 0 Output -
4	Ch 1 Input +	17	Ch 1 Output Common
5	Ch 1 Input -	18	Ch 1 Output +
6	Ch 1 Input Common	19	Ch 1 Output -
7	Ch 2 Input +	20	Ch 2 Output Common
8	Ch 2 Input -	21	Ch 2 Output +
9	Ch 2 Input Common	22	Ch 2 Output -
10	Ch 3 Input +	23	Ch 3 Output Common
11	Ch 3 Input -	24	Ch 3 Output +
12	Ch 3 Input Common	25	Ch 3 Output -
13	Power On Indicator		



## Audio Signal Processing Board Connector

The Audio digital Signal Processor board (ASPB) accepts 16 channels of digital audio input and provides 16 channels of digital audio output via a 80-pin connector on the rear panel. The cable to this connector is from the Profile Audio Chassis or from the XLR/BNC 216 Digital Breakout Box. Figure B-8 shows the ASPB rear panel connector and Table B-8 lists the pin-outs.

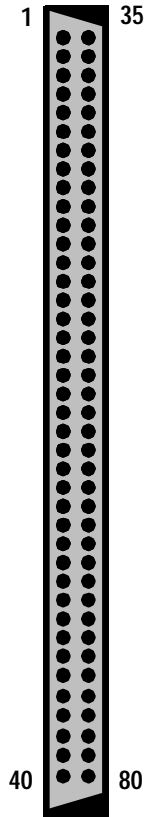

Figure B-8. ASPB Connector



**Table B-8. ASPB Connector Pin-outs**

Pin	Signal Description	Pin	Signal Description	Pin	Signal Description
1	Ch 1-2 AES Out (P)	28	nc	55	Ch 15-16 AES Out (P)
2	Ch 1-2 AES Out (N)	29	Ch 13-14 AES In (P)	56	Ch 15-16 AES Out (N)
3	Chassis Ground	30	Ch 13-14 AES In(N)	57	Ch 1-4 ADC Clock Out (P)
4	Chassis Ground	31	AES Reference In (P)	58	Ch 1-4 ADC Clock Out (N)
5	Ch 5-6 AES Out (P)	32	AES Reference In (N)	59	Ch 3-4 AES In (P)
6	Ch 5-6 AES Out (N)	33	AES Monitor Out (P)	60	Ch 3-4 AES In (N)
7	nc	34	AES Monitor Out (N)	61	Ch 5-8 ADC Clock Out (P)
8	nc	35	nc	62	Ch 5-8 ADC Clock Out (N)
9	Ch 9-10 AES Out (P)	36	nc	63	Ch 7-8 AES In (P)
10	Ch 9-10 AES Out (N)	37	UART Receive (P)	64	Ch 7-8 AES In (N)
11	nc	38	UART Receive (N)	65	Ch 9-12 ADC Clock Out (P)
12	nc	39	PAC Ready (P)	66	Ch 9-12 ADC Clock Out (N)
13	Ch 13-14 AES Out (P)	40	PAC Ready (N)	67	Ch 11-12 AES In (P)
14	Ch 13-14 AES Out (N)	41	nc	68	Ch 11-12 AES In (N)
15	nc	42	nc	69	Ch 13-16 ADC Clock Out (P)
16	nc	43	Ch 3-4 AES Out (P)	70	Ch 13-16 ADC Clock Out (N)
17	Ch 1-2 AES In (P)	44	Ch 3-4 AES Out (N)	71	Ch 15-16 AES In (P)
18	Ch 1-2 AES In (N)	45	nc	72	Ch 15-16 AES In (N)
19	nc	46	nc	73	Digital Ground
20	nc	47	Ch 7-8 AES Out (P)	74	Breakout Box Present Flag
21	Ch 5-6 AES In (P)	48	Ch 7-8 AES Out N)	75	UART Transmit (P)
22	Ch 5-6 AES In (N)	49	nc	76	UART Transmit (N)
23	nc	50	nc	77	Chassis Ground
24	nc	51	Ch 11-12 AES Out (P)	78	Chassis Ground
25	Ch 9-10 AES In (P)	52	Ch 11-12 AES Out (N)	79	PAC Reset (P)
26	Ch 9-10 AES In (N)	53	nc	80	PAC Reset (N)
27	nc	54	nc		

nc = no connection

# Index

## A

- Accessories 1-6
  - Optional 1-7
  - Standard 1-6
- AES/EBU Audio Breakout Panel 2-15
- Analog Audio
  - 8 Channel Analog Audio 2-20
- Analog Audio Mode Specifications A-9
- Analog Audio, Connecting
  - 16 Channel Analog Audio 2-22
  - 32 Channels Analog Audio 2-24
  - 8 Channels Analog Audio 2-20
- Analog Composite Video I/O Specifications A-4
- Analog Composite Video Output Specifications A-3
- Analog Composite Video, connecting 2-11, 2-12, 2-13
- ASPB 2-15
- Audio Channel Assignment 2-16
- Audio Interface Chassis 2-15
- Audio Signal Processing Board Connector B-9
- Automatic Logon 3-1, 3-2

## B

- BNC216 audio breakout box 2-15

## C

- Canadian Certified AC Adapter xi
- Canadian Certified Power Cords xi
- Canadian EMC Notice of Compliance xi
- Certification xii
- Component Analog Video Input Specifications A-5
- Component Analog Video Performance Specifications A-5
- Component Analog Video, Connecting 2-14
- Configuration Labels 1-14
- Configurations, system 1-8
- Configuring Ethernet for TCP/IP 4-5

- Configuring Your Profile 3-6
- Connecting AES/EBU Digital Audio 2-16, 2-18
- Connecting Analog Composite Monitor 2-12
- Connecting Analog Composite Video I/O 2-11
- Connecting Analog Composite Video Out 2-13
- Connecting Audio
  - 16 Channel Analog and/or Digital 2-22
  - 16 Channels AES/EBU Digital Only 2-16
  - 32 Channel Analog and/or Digital 2-24
  - 32 Channels AES/EBU Digital Only 2-18
  - 8 Channels Analog and/or Digital 2-20
  - General overview 2-15
  - One PAC216 Analog Audio Chassis 2-22
  - PAC208 Analog Audio Chassis 2-20
  - Two PAC216 Analog Audio Chassis 2-24
- Connecting Component Analog Video 2-14
- Connecting Ethernet 2-33, 4-4
- Connecting Fibre Channel 2-33
- Connecting Network Devices
  - Ethernet 2-33
  - Fibre Channel 2-33
- Connecting RS-422 Devices 2-32
- Connecting SCSI Devices 2-26
- Connecting Serial Digital Video 2-10
- Connecting the Monitor 2-8
- Connecting the Mouse and Keyboard 2-8
- Connecting the Reference Genlock 2-9
- Connecting Video 2-10
  - Analog Composite Video In 2-11
  - Analog Composite Video Out 2-13
  - Component Analog Video In 2-14
  - Serial Digital 2-10
- Connector Pin-outs B-1
  - Audio Signal Processing Board Connector B-9
  - Ethernet Connector B-2
  - Fibre Channel Connector B-7
  - Parallel Port Connector B-3
  - Reference Genlock Connector B-8
  - RS-232 Connector B-4
  - S-VGA Connector B-1
- Controls, Front Panel 1-5



**D**

- Data Rates 1-15
- Diagnostics 3-9
- Digital Audio, connecting 2-16, 2-18, 2-20, 2-22, 2-24
- DVCPRO 1-3, 1-8, 1-13, 1-16
- DVCPRO Restrictions
  - system timing 1-17
  - when used with JPEG 1-17

**E**

- Electrical Characteristics
  - Power Source A-9
- Electrical Specifications A-2
  - Power Supply A-10
  - Reference Genlock A-2
  - Time Code A-2
- EMI suppression gasket, BNC connector 2-7
- EN55022 Class A Warning xi
- Environmental Criteria A-10
- Ethernet Connector B-2
- Ethernet Network Setup
  - Configuring Ethernet TCP/IP 4-5
  - Connecting Ethernet 4-4
  - Ethernet Crossover Cable 4-3
  - Testing Your Ethernet Connection 4-5
- Ethernet, Connecting 2-33

**F**

- FCC Emission Control xi
- FCC Emission Limits xii
- Fibre Channel board 2-33
- Fibre Channel board, connecting 2-33
- Fibre Channel Cable Specifications B-7
- Fibre Channel Connector B-7
- Fibre Channel Network Setup 4-6
- Format Voltage Level Definitions for CAVmtrxN Colorbar Matrix Test Clip A-6
- Format Voltage Level Definitions for CAVmtrxP Colorbar Matrix Test Clip A-7
- Front Panel Controls and Indicators 1-5

**G**

- General Information, Specifications A-1

- General Safety Summary ix

**H**

- house reference signal, connecting 2-9

**I**

- Indicators, Front Panel 1-5
- Initial Power On Checks 3-7
- Injury Precautions ix
- Installation Verification 3-7
- Introduction 1-1

**J**

- JPEG 1-3, 1-8

**L**

- Laser Compliance xi
  - FCC Emission Limits xii
  - Laser Safety xii
  - Laser Safety Requirements xi
- Laser Safety xii
- Laser Safety Requirements xi
- Logging On 3-1
  - Automatic Logon 3-1
  - Logon as Administrator 3-2
  - Logon as Profile User 3-2
- Longitudinal Time Code breakout cable 2-9

**M**

- Making Power Connections 2-34
  - Power Source 2-34
  - Source Power Frequency and Voltage Ranges 2-34
- Making Rack Slide Adjustments 2-6
- Making Rear Panel Connections 2-7
- Manual, Organization 1-2
- Master Enhanced Disk Recorder Board 2-26
- Maximum Video Data Rates 1-15
- Mechanical Installation 2-1
- Mechanical Specifications A-11
- Monitor, Connecting 2-8
- Mounting Panels and Audio Chassis 2-6
- Mounting the Profile Video File Server 2-5
- Mounting the Slide Tracks in the Rack 2-2
- Mounting, Rack 2-1
- Mouse, Connecting 2-8

MPEG 1-3, 1-8

## N

Network Configurations 4-1

Network Models 4-1

    Cascading Several Hubs 4-2

    Networking Several Profiles 4-2

    Point to Point Network Connection 4-3

Networking Several Profiles 4-2

Networking Your Profile 4-1

## O

Optional Accessories 1-7

Organization of the Manual 1-2

## P

PAC208 Profile Audio Chassis 2-15

PAC216 Profile Audio Chassis 2-15, 2-24

PDR 200, Description 1-3

PDR 300, Description 1-3

PDR 400, Description 1-3

PDX 218 Disk Expansion

    Connecting 2-27, 2-28

    Storage Capacity 1-16

Point to Point Network Connection 4-3

Power On/Off 3-1

Power Source 2-34, A-9

Power Supply Specifications A-10

Product Damage Precautions ix

Product Description 1-3

Product Features 1-4

Profile Library System 2-29

Profile Video Networking 2-33

## R

Rack Mounting 2-1, 2-5

    Mounting the Slide Tracks in the Rack 2-2

RAID Storage chassis 2-31

Rear Panel Connections 2-7

Rear Panel LEDs 3-8

Reference Genlock board 2-9

Reference Genlock D-Connector B-8

Reference Genlock Specifications A-8

Reference Genlock, Connecting 2-9

Related Documentation 1-2

RS232 Connector

Connector Pin-outs B-4

RS-422 Connector Panel 2-32

    Connections 2-32

    Dip Switch Settings 2-32

RS-422 Devices, Connecting 2-32

## S

Safety Terms and Symbols x

Scope 1-1

SCSI

    Connector 2-26

SCSI Devices

    Disk Expansion 2-27, 2-28

    Profile Library System 2-29

    RAID Storage 2-31

Serial Digital Video I/O

    Connecting 2-10

    Specifications A-2

Slave Enhanced Disk Recorder Board 2-26

Slave Enhanced Disk Recorder Connection  
2-26

Source Power 2-34, A-9

Source Power Frequency 2-34

Source Power Frequency and Voltage Ranges  
2-34

Source Power Voltage Ranges 2-34

Specification

    Electrical Characteristics

        Power Source A-9

Specifications A-1

    Analog Audio Mode A-9

    Analog Composite Video I/O A-4

    Analog Composite Video Output A-3

    Component Analog Video Input A-5

    Component Analog Video Performance  
A-5

    Electrical A-2

    Environmental A-10

    Fibre Channel Cable B-7

    Mechanical A-11

    Power Supply A-10

    Reference Genlock A-8

    Serial Digital I/O A-2

    Time Code A-8

Standard Accessories 1-6



**Starting Your Profile**

See also Automatic Logon 3-1

Storage Capacity 1-16

S-VGA Connector B-1

System Bandwidth 1-16

System Board Diagnostics 3-9

System Set-up 3-5

**T**

Test Equipment A-1

Testing Your Ethernet Connection 4-5

Time Code Specification A-8

Turning Power Off 3-4

Turning Power On 3-2

**U**

Updating an Emergency Repair Disk 3-6

**V**

video clock reference 2-9

Video Data Rates 1-15

**X**

XLR216 audio breakout box 2-15, 2-16, 2-18